

BALERI ITALIA

**Sustainable
Freedom**

2025

BALERI ITALIA

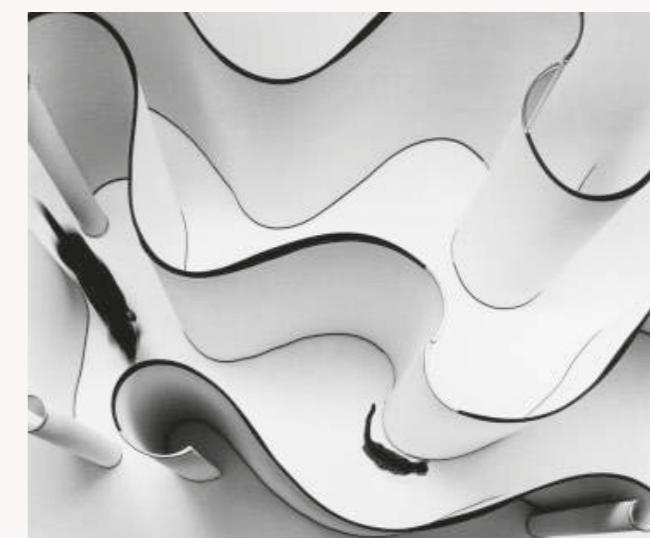

2

3

Italian design since 1984

Baleri Italia was founded on 8 March 1984 by Enrico Baleri and Marilisa Decimo.

In the years of sobriety and form-function rigour, Baleri Italia became the highest expression of a certain idea of design, pragmatic and at the same time utopian, in pursuit of the authentic, non-obsolescent, inconspicuous, coherent, international object.

Its design philosophy was and remains aimed at creating distinctive and functional design, maintaining a constant commitment to expressive research combined with careful technical product development.

This approach has enabled the company to pioneer technological experimentation and material innovation, as well as recognising and supporting emerging talents in design.

Today the evolution continues, through the rethinking of the brand identity according to the current context.

Design italiano dal 1984

Baleri Italia è stata fondata l'8 marzo 1984 da Enrico Baleri e Marilisa Decimo.

Negli anni della sobrietà e del rigore forma-funzione, Baleri Italia diventa la massima espressione di una certa idea di design, pragmatica e insieme utopica, all'inseguimento dell'oggetto autentico, non obsolecente, non appariscente, coerente, internazionale.

La sua filosofia progettuale era e rimane volta alla creazione di un design distintivo e funzionale, mantenendo un costante impegno verso la ricerca espressiva coniugata a un attento sviluppo tecnico del prodotto.

Questo approccio ha permesso all'azienda di essere pioniera nella sperimentazione tecnologica e nell'innovazione dei materiali, nonché nel riconoscimento e nel sostegno dei talenti emergenti nel design.

Oggi l'evoluzione continua, attraverso il ripensamento dell'identità del marchio alla luce del contesto attuale.

SUSTAINABLE FREEDOM



1



3

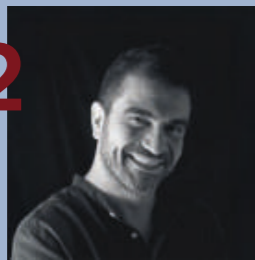

2



4



6

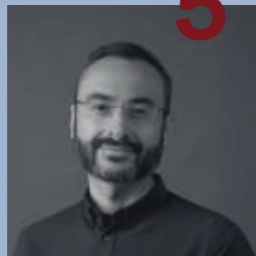

5

Creative Advisory Board

1 - Alice Ballabio
Creative Strategist for Oniro Group and Baleri Italia.

Creative Strategist per Oniro Group e Baleri Italia.

2 - Andrea Puppa
Graphic designer and co-founder of the cccppp studio.

Graphic designer e co-fondatore dello studio cccppp.

3 - Franco Raggi
Architect, designer, curator and editor for Casabella.

Architetto, designer, curatore ed editor per Casabella.

4 - Odoardo Fioravanti
Designer, professor and winner of a Compasso d'Oro award.

Designer, docente e vincitore di un Compasso d'Oro.

5 - Stefano Caggiano
Design critic and professor at Istituto Marangoni.

Critico del design e docente presso l'Istituto Marangoni.

6 - Stephan Hamel
Design consultant and curator.
Consulente di design e curatore.

MANIFESTO

The design brand as a cultural actor

The true value of design lies in its ability to resonate with users.

A design brand is not just a commercial enterprise, but a cultural actor that contributes to the creation of new product languages that can resonate with users' sensibilities, defined by the cultural context in which they live.

This requires a long-term understanding of users that goes beyond commercial readings to capture their deep anthropological needs.

This is the only way for a design proposal to be perceived as meaningful.

1 - Between technical rationalism and postmodernism

Responsible freedom as a way of integrating expression and rigour.

Baleri Italia's design identity is born from the union of two fundamental strands of design culture: techno-rationalism and postmodernism.

In the current context, they are evolving towards a new concept of responsible freedom that synthesises the dual response to a key issue of our time, outlining a design strategy based on the integration of expressive charge and formal rigour in the product.

2 - The age of dual sustainability

Meaning and value of design derive from its ability to respond to the double need for sustainability of our time.

In line with its dual identity, Baleri Italia today proposes a response to the dual need for lightness that characterises the contemporary user, due on the one hand to the growing attention to the consequences of the environmental impact of the production of objects (environmental sustainability), and on the other to the cognitive overload that the age of information and digital sociality imposes on everyone (cognitive sustainability).

The approach to design must be both materially and conceptually light, and therefore meaningful, as it responds to the dual need for sustainability in our time.

Il brand di design come attore culturale

Il valore profondo del design consiste nella sua capacità di risuonare con gli utenti.

Un brand di design non è solo un'impresa commerciale ma un attore culturale, che contribuisce alla creazione di nuovi linguaggi di prodotto in grado entrare in risonanza con la sensibilità degli utenti, a sua volta definita dal contesto culturale in cui vivono.

Ciò richiede una comprensione lunga degli utenti, che vada oltre la lettura commerciale per intercettarne i bisogni antropologici profondi.

Solo così è possibile realizzare una proposta di design percepita come significativa.

1 - Tra razionalismo tech e postmoderno

Libertà responsabile come via all'integrazione di espressione e rigore.

La design identity di Baleri Italia è nata dall'unione di due filoni fondamentali della cultura del design, razionalismo tech e postmoderno.

Declinati nel contesto attuale, essi evolvono in direzione di un nuovo concetto di libertà responsabile, che sintetizza la doppia risposta a un tema chiave del nostro tempo, delineando una strategia di design basata sull'integrazione della carica espressiva e del rigore formale nel prodotto.

2 - L'epoca delle due sostenibilità

Senso e valore del design nascono dalla sua capacità di rispondere al doppio bisogno di sostenibilità del nostro tempo.

In linea con la sua doppia identità, Baleri Italia propone oggi una risposta al doppio bisogno di leggerezza che contraddistingue l'utente contemporaneo, dovuta da un lato alla crescente attenzione per le conseguenze dell'impatto ambientale della produzione di oggetti (sostenibilità ambientale), dall'altro al sovraccarico cognitivo che l'epoca dell'informazione e della socialità digitale pone a ogni singolo individuo (sostenibilità cognitiva).

L'approccio al design deve essere leggero sia da un punto di vista materiale che concettuale e per questo sensato, in quanto rispondente al doppio bisogno di sostenibilità del nostro tempo.

Manifesto for the new course of Baleri Italia

In 2024, its fortieth anniversary, Baleri Italia is carried out a profound reflection on its identity and prospects for the future.

To tackle this path in the best possible way, a Creative Advisory Board was set up, coordinated by design critic Stefano Caggiano.

Composed of personalities from a variety of professional backgrounds, the Creative Advisory Board had the aim of outlining a new perspective for Baleri Italia: a future of sustainable freedom for a brand that sees itself as a cultural player.

Un manifesto per il nuovo corso di Baleri Italia

Nel 2024, suo quarantesimo anniversario, Baleri Italia ha attuato una profonda riflessione sulla propria identità e sulle prospettive per il futuro.

Per affrontare al meglio questo percorso, è stato costituito un Creative Advisory Board coordinato dal critico del design Stefano Caggiano.

Composto da personalità provenienti da diverse esperienze professionali, il Creative Advisory Board si è posto l'obiettivo di tracciare una nuova prospettiva per Baleri Italia: un futuro di libertà sostenibile per un brand che si pone come un attore culturale.

3 - The light project: Sense & Sensibility

The new evolution of Baleri Italia's specific dual identity is characterised by a light approach to project, given by the double lightening through design.

Starting from the evolution of Baleri Italia's dual identity, given by the combination of postmodernism and technical rationalism, the concept of sustainable freedom, central to the new strategic direction, takes shape.

The combination of formal cleanliness and aesthetic attention brings a light approach to the project, both from a material and a conceptual point of view, offering highly sustainable solutions that integrate sense & sensibility in a perspective of mutual revitalisation, a lively dialogue between rationality and expressiveness that defines the identity of Baleri Italia in the strict sense, and of Italian design culture in the broader sense.

4 - The “why” for the new Baleri Italia

Baleri Italia's “legitimacy” lies in being the guardian of the beating heart of Italian design culture.

The revitalised combination of technology and post-modern rationalism sets the direction for the new phase of the brand, which is pursuing the path of a double lightening through a light and sensible approach to design.

From this unique position in the design scene, Baleri Italia offers a product that is commercially accessible, particularly (but not only) suitable for new generations, and full of meaning at a cultural level, as the guardian of the beating heart from which Italian design culture springs, historically shaped by the never-ending dialogue between the need for reason and the need for expression.

5 - A dialogical catalogue

Baleri Italia's catalogue is the guardian of a dialogical structure that puts techno-rationalism and postmodernism in relation to each other.

In accordance with its cultural identity and mission, Baleri Italia aims to develop a dialogical catalogue where both products inspired by techno-rationalism or by postmodernism will find a place.

These products will not be included in the catalogue with a static value, but with a dynamic one: the catalogue will host, on the one hand, rational-technological products moved by a postmodern touch and, on the other hand, postmodern products softened by a rational-tech touch, so that the two souls will revamp each other.

This strategy will be implemented through both the relaunch of iconic products and the introduction of new ones, creating a soft brand identity that combines flexibility and consistency.

3 - Il progetto lieve: Sense & Sensibility

La nuova evoluzione della doppia identità specifica di Baleri Italia si caratterizza per un approccio lieve al progetto, dato dal doppio alleggerimento attraverso il design.

A partire dall'evoluzione della doppia identità di Baleri Italia, data dal combinato disposto di postmoderno e razionalismo tech, prende forma il concetto di libertà sostenibile, centrale nella nuova direzione strategica.

Unendo pulizia formale e attenzione estetica si dà corpo a un approccio lieve al progetto, sia da un punto di vista materiale che concettuale, offrendo soluzioni doppiamente sostenibili che integrano ragione e sentimento (sense & sensibility) in una prospettiva di rilancio reciproco, un vivo “dialogo” tra razionalità ed espressività che definisce l'identità di Baleri Italia in senso stretto e della cultura italiana del design in senso lato.

4 - Il “perché” della nuova Baleri Italia

La “legitimacy” di Baleri Italia risiede nel suo essere custode del cuore vivo della cultura italiana del design.

La rivitalizzata combinazione di razionalismo tech e postmoderno traccia la direzione per la nuova fase del brand, che attraverso un approccio lieve e sensato al progetto persegue la via del doppio alleggerimento.

Da questo posizionamento unico nel panorama del design Baleri Italia offre un prodotto accessibile sul piano commerciale, adatto in particolare (ma non solo) alle nuove generazioni, e pieno di significato sul piano culturale, in quanto custode del cuore vivo da cui scaturisce la cultura italiana del design, che ha preso forma storicamente dal dialogo mai sopito tra necessità della ragione e bisogno di espressione.

5 - Un catalogo “dialogico”

Il catalogo di Baleri Italia mantiene in sé, nel ruolo di custode, la struttura dialogica che mette in relazione razionalismo tech e postmoderno.

Coerentemente con la sua identità e la sua missione culturale, Baleri Italia punta allo sviluppo di un catalogo dialogico, nel quale trovino spazio sia prodotti ispirati al razionalismo tech che prodotti ispirati al postmoderno.

Tali prodotti non saranno inseriti a catalogo con un valore statico, ma dinamico: il catalogo ospiterà da un lato prodotti razional tech mossi da un tocco postmoderno, e dall'altro prodotti postmoderni mitigati da un tocco di razional tech, in modo che le due anime si rilancino a vicenda.

Questa strategia si attuerà sia attraverso la riedizione dei prodotti iconici che attraverso l'inserimento di nuovi prodotti, dando corpo a una brand identity morbida che unisce flessibilità e coerenza.

6 - Authority and responsibility

Dialogic identity restores Baleri Italia's authorship, integrated with a responsible approach to be transparently communicated.

The concept of an intrinsically dialogic soft identity restores Baleri Italia's traditional authorship in the design world, which in the new course is combined with the theme of responsibility, to be communicated transparently, showing how Baleri Italia does things.

In this perspective, the integration of design, communication and distribution becomes essential to ensure the correct transmission of the brand value and to spread a clear image that appears reasonable to the customer.

7 - Lightweight product and dense communication

Material lightness and enhanced communication combine sustainability and freedom of expression.

In the current context, in which the search for material lightness in production is emphasised on the one hand, and the increased weight of digital communication on the other, Baleri Italia's integrated strategy (in which design, communication and distribution work together to create value) is naturally in line with this duality, balancing the physical lightness of products and the density of digital communication, thus combining attention to product sustainability with expressive freedom of communication.

6 - Autorialità e responsabilità

Senso e valore del design nascono dalla sua capacità di rispondere al doppio bisogno di sostenibilità del nostro tempo.

Il concetto di identità morbida intrinsecamente dialogica restituisce a Baleri Italia la sua tradizionale autorialità nel mondo del design, che nel nuovo corso si unisce al tema della responsabilità da comunicare in modo trasparente, mostrando come Baleri Italia fa le cose.

In questa prospettiva, l'integrazione tra design, comunicazione e distribuzione diventa essenziale per garantire la corretta trasmissione del valore del brand e diffondere un'immagine nitida che appaia sensata ai clienti.

7 - Prodotto leggero e comunicazione densa

Leggerezza materiale e comunicazione aumentata uniscono sostenibilità e libertà espressiva.

Nell'attuale contesto, in cui vengono valorizzati da un lato la ricerca di una leggerezza materiale della produzione, e dall'altro un aumento di peso nella comunicazione digitale, la strategia integrata di Baleri Italia (che vede cooperare design, comunicazione e distribuzione per creare valore) si allinea naturalmente a questa dualità, bilanciando leggerezza fisica dei prodotti e densità della comunicazione digitale, unendo così l'attenzione alla sostenibilità del prodotto alla libertà espressiva della comunicazione.

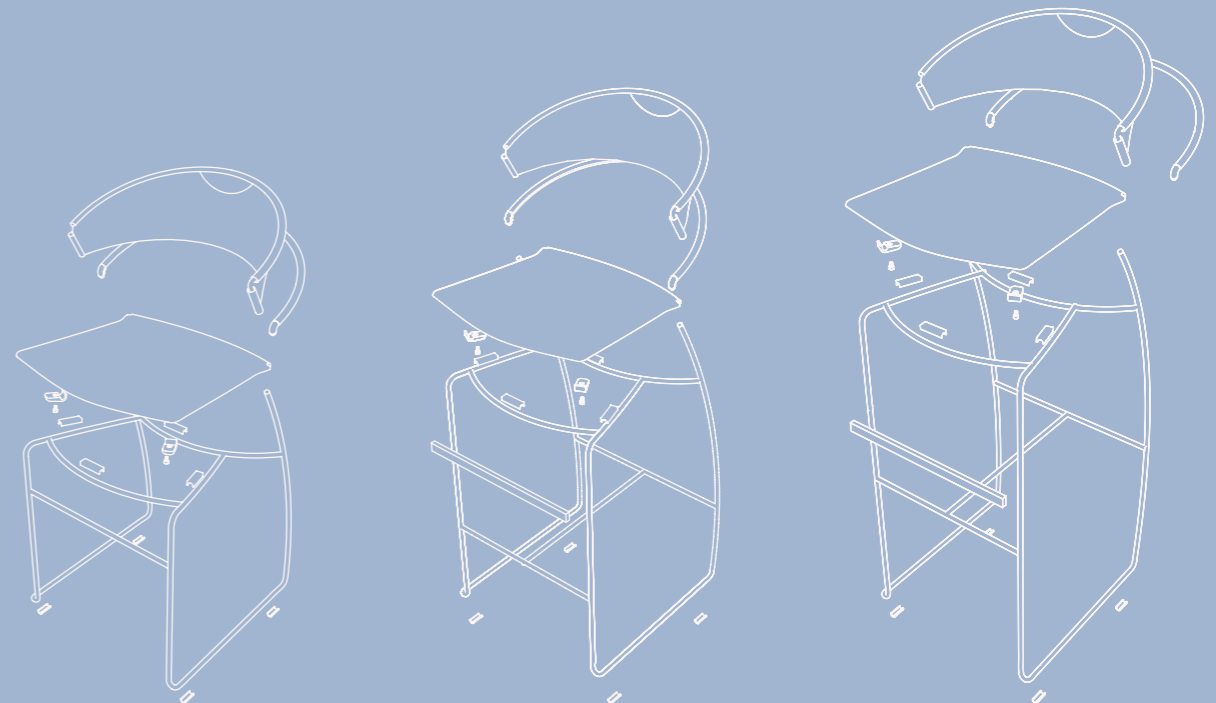

TIMELINE

1984



Café Chair PS210/3
Philippe Starck



Mac Gee PS209
Philippe Starck



President M PS203/4
Philippe Starck



Richard III PS215
Philippe Starck



Juliette HW601/9
Hannes Wettstein



Caprichair HW620/4
Hannes Wettstein



Capri Jolly HW630/6
Hannes Wettstein

1992

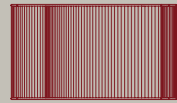

Cartoons LB901/2
Luigi Baroli



Bill HW641/5
Hannes Wettstein



Mama DS852/4
Denis Santachiara



Tato DS855
Denis Santachiara



Tatino ED860
Enrico Baleri



Tatone ED870
Enrico Baleri



Lunella EB880
Enrico Baleri



T-Table MM450/6
Angelo Mangiarotti

8

2001



Tato Bean EB872
Enrico Baleri



Tato Bonbon EB871
Enrico Baleri



Bentz JM201/2
Jeff Miller

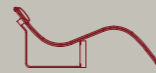

Flipt JM301
Jeff Miller



Obo JM401
Jeff Miller



Fratino JM206
Jeff Miller



Kin OD101/3
Radice Orlandini

2005

2019



Miss Match CKR300/6
Claesson Koivisto Rune



Roundel CKR201
Claesson Koivisto Rune



Donna IR101/3
Studio Irvine



Paloma OD104
Radice Orlandini



Bermuda CKR310
Claesson Koivisto Rune



InBallo OF201/2
Odo Fioravanti



Roots AL210/3
Arik Levy



Spunta OF301
Odo Fioravanti

1987

1990

1991

1997

1998

2007

2009

2018

2020

2025

9

Tatino, pouf
Miss Match, sofa/divano
InBallo, low table/tavolino
Cartoons, screen/paravento



Tatino, pouf
Miss Match, sofa/divano
InBallo, low table/tavolino
Cartoons, screen/paravento



12



13

Tatino, pouf
Miss Match, sofa/divano
InBallo, low table/tavolino
Cartoons, screen/paravento



Miss Match, sofa/divano
InBallo, low table/tavolino



InBallo, low table/tavolino

Miss Match, sofa/divano
InBallo, low table/tavolino



Tatino, pouf
Miss Match, sofa/divano
InBallo, low table/tavolino
Cartoons, screen/paravento





Roundel, table/tavolo

Donna, chair/sedia
Roundel, table/tavolo



Roots, table/tavolo
Obo, container/contentitore
Tato, pouf



Tato, pouf
Obo, container/contentitore



Paloma, chair/sedia
Roots, table/tavolo



Paloma, chair/sedia
Roots, table/tavolo
Obo, container/contenitore



Tatino, pouf
Cartoons, screen/paravento
Juliette, chair/sedia
T-Table, table/tavolo



T-Table, table/tavolo
Mac Gee, bookshelf/libreria



Cartoons, screen/paravento
Juliette, chair/sedia
T-Table, table/tavolo

Tatino, pouf
Cartoons, screen/paravento



Caprichair, armchair/poltrona
T-Table, low table/tavolino



Caprichair, armchair/poltrona



Juliette, chair/sedia

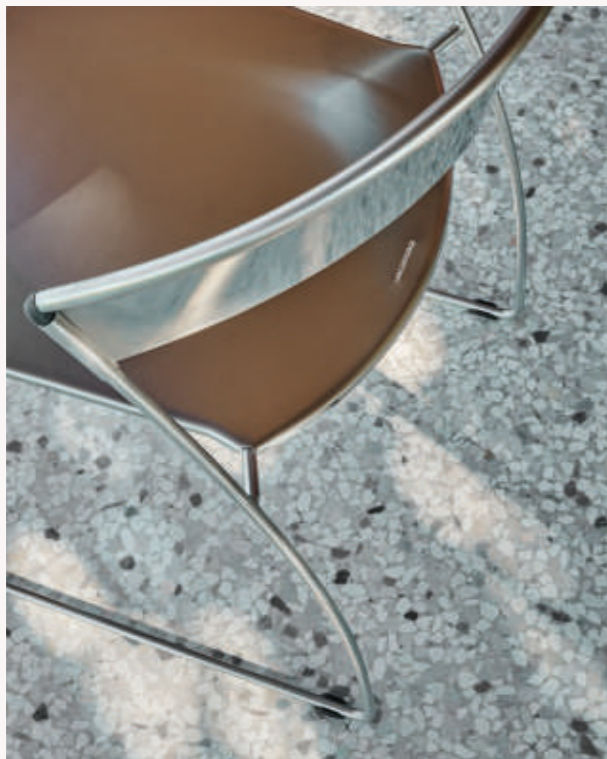

Juliette, chair/sedia

Juliette, chair/sedia



Mama, armchair/poltrona
Cartoons, screen/paravento
Tato, pouf
Bentz, low table/tavolino



Bentz, low table/tavolino



Mama, armchair/poltrona
Cartoons, screen/paravento



Tato, pouf
Mama, armchair/poltrona
Cartoons, screen/paravento

Donna, chair/sedia



Donna, chair/sedia



Café Chair, chair/sedia
President M, table/tavolo



President M, table/tavolo
Café Chair, chair/sedia



Café Chair, chair/sedia
President M, table/tavolo



Café Chair, chair/sedia

InBallo, low table/tavolino
Bermuda, armchair/poltrona
Tato, pouf
Cartoons, screen/paravento



Bermuda, armchair/poltrona
Cartoons, screen/paravento
InBallo, low table/tavolino



46



Bermuda, armchair/poltrona
InBallo, low table/tavolino

47



Roots, bar table/tavolo bar
Café Chair, stool/sgabello



Café Chair, stool/sgabello
Roots, bar table/tavolo bar

Roots, bar table/tavolo bar
Café Chair, stool/sgabello



Bill, sofa/divano
Bill, armchair/poltrona
Roots, low table/tavolino







Bill, sofa/divano



Tatone, pouf

Roots, low table/tavolino
Bill, sofa/divano
Bill, armchair/poltrona



Caprilarge, armchair/poltrona
Fratino, table/tavolo



Fratino, table/tavolo



Caprilarge, armchair/poltrona
Fratino, table/tavolo

Capri large, armchair/poltrona
Fratino, table/tavolo





Bentz, table/tavolo

Kin, chair/sedia

Bentz, table/tavolo
Kin, chair/sedia



Bentz, table/tavolo
Kin, chair/sedia

Paloma, chair/sedia



Donna, chair/sedia
Juliette, chair/sedia
Paloma, chair/sedia

Tatone, pouf
Mac Gee, bookshelf/libreria
Richard III, armchair/poltrona
Roots, low table/tavolino

66



Tatino, pouf
Tatone, pouf
Roots, low table/tavolino



67

Mac Gee, bookshelf/libreria
Tatino, pouf
Tatone, pouf

Tatone, pouf
Spunta, armchair/poltrona
T-Table, low table/tavolino



T-Table, low table/tavolino
Spunta, armchair/poltrona



Spunta, armchair/poltrona



T-Table, console/consolle
Cartoons, screen/paravento

T-Table, console/consolle
Cartoons, screen/paravento
Tatino, pouf
Tatone, pouf





74

75

Cartoons, screen/paravento
Roundel, table/tavolo

Cartoons, screen/paravento
Roundel, table/tavolo
Juliette, chair/sedia



Roundel, table/tavolo



Cartoons, screen/paravento
Roundel, table/tavolo
Juliette, chair/sedia



Cartoons, screen/paravento
Spunta, armchair/poltrona



Cartoons, screen/paravento
Obo, container/contenitore
Spunta, armchair/poltrona

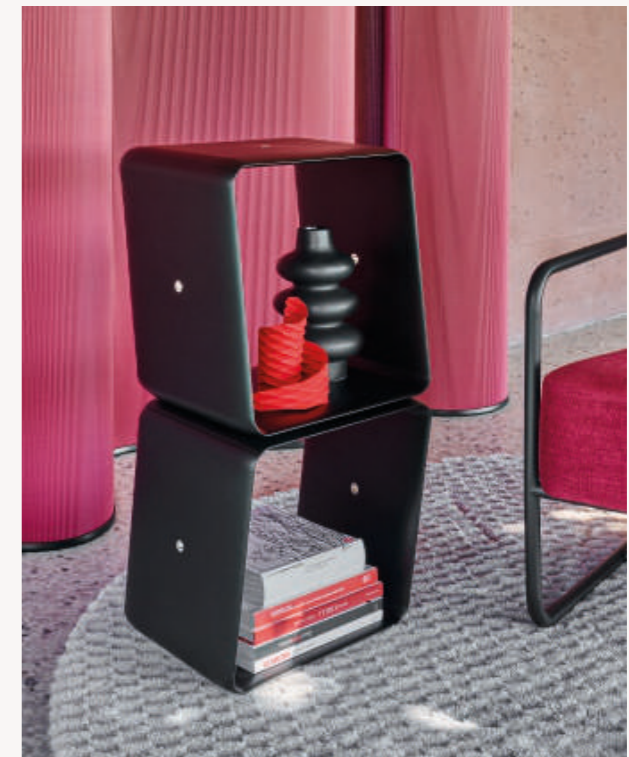

Cartoons, screen/paravento
Obo, container/contenitore
Spunta, armchair/poltrona

Capri Jolly, armchair/poltrona
T-Table, low table/tavolino



82



83

Capri Jolly, armchair/poltrona
T-Table, low table/tavolino

Flipt, chaise-longue
Obo, container/contenitore







Obo, container/contenitore
 Flipt, armchair/poltrona
 Lunella, pouf

Obo, container/contenitore
 Flipt, armchair/poltrona
 Lunella, pouf



Juliette, stool/sgabello



Juliette, stool/sgabello

Cartoons, screen/paravento
Tato Bonbon, pouf
Tato Bean, pouf
Lunella, pouf



Tato Bonbon, pouf
Tato Bean, pouf
Lunella, pouf

INDEX INDICE

Collection	Enrico Baleri	96
Collezione	Tato Collection	98
	Luigi Baroli	102
	Cartoons	104
	Claesson Koivisto Rune	108
	Bermuda	110
	Miss Match	114
	Roundel	118
	Odo Fioravanti	122
	InBallo	124
	Spunta	128
	Marialaura Irvine	132
	Donna	134
	Arik Levy	138
	Roots	140
	Angelo Mangiarotti	144
	T-Table	146
	Jeff Miller	152
	Bentz	154
	Flipt	160
	Fratino	164
	Obo	168
	Radice Orlandini	172
	Kin	174
	Paloma	178
	Denis Santachiara	182
	Mama	184
	Tato	188
	Philippe Starck	192
	Café Chair	194
	Mac Gee	198
	President M	202
	Richard III	206
	Hannes Wettstein	210
	Bill	212
	Capri Collection	216
	Juliette	220

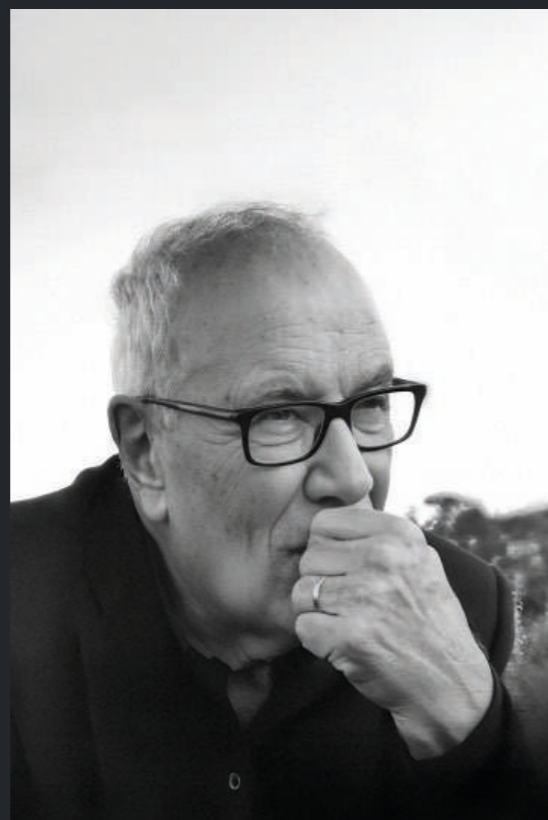

Enrico Baleri

Born in Albino (BG) in 1942.

In 1984 he founded Baleri Italia with Marilisa Decimo, working with Hollein, Mendini and the newcomers Dalisi, Starck and Wettstein to create a unified collection.

From 1989 to 1992 he chaired the Associazione Casa Malaparte for the cultural re-evaluation of the famous architectural masterpiece of the island of Capri.

In 1994 he founded the Italian Committee AALTO/Viipuri, involving companies and professionals in a collective operation to collect private contributions for the Viipuri Library, Alvar Aalto's masterpiece on Russian territory.

In 2004, together with Marilisa Decimo and Luigi Baroli, he founded the eb&c research centre, collaborating with Cerruti Baleri and other companies in product development.

Nasce a Albino (BG) nel 1942.

Nel 1984 con Marilisa Decimo fonda Baleri Italia e collabora con Hollein, Mendini e con gli esordienti Dalisi, Starck, Wettstein alla formazione di una collezione unitaria.

Dal 1989 al 1992 presiede l'Associazione Casa Malaparte per la rivalutazione culturale del celebre capolavoro di architettura nell'isola di Capri.

Nel 1994 fonda il Comitato Italiano AALTO/Viipuri e coinvolge imprese e professionisti in una operazione collettiva capace di raccogliere contributi privati a favore della Biblioteca di Viipuri, capolavoro di Alvar Aalto in territorio russo.

Nel 2004 fonda con Marilisa Decimo e Luigi Baroli il centro ricerche eb&c, collaborando con Cerruti Baleri ed altre aziende allo sviluppo di prodotti.



Tato Collection, design Enrico Baleri

TATO COLLECTION

98



Enrico Baleri 1997/2001

Tato Collection is a family of poufs or footrests with a rigid base and different shapes, made of flexible material. The removable cover, easy to replace, is made of bi-elastic fabric, available in many colours.

A family of minimalist objects, with Tato as its prototype: in collaboration with the founder of Baleri Italia, Enrico Baleri, the first pouf designed by Denis Santachiara became a wider collection. A project with a strong visual and chromatic impact, which does not neglect the functional element: versatile and creative, the Tato Collection poufs suggest ways of use without imposing fixed paths or rigid interpretations, offering true sustainable freedom.

Tato Collection è una famiglia di pouf o poggiatesta con base rigida e diverse forme, realizzati in materiale flessibile. Il rivestimento sfoderabile, facile da sostituire, è in tessuto bi-elastico, disponibile in tantissimi colori.

Una famiglia di oggetti minimalisti, il cui capostipite è Tato: dal primo pouf ideato da Denis Santachiara, prende forma una collezione più ampia, sviluppata in collaborazione con il fondatore di Baleri Italia, Enrico Baleri. Un progetto dal forte aspetto visivo e cromatico, che non trascura l'elemento funzionale. Versatili e creativi, i pouf della Tato Collection suggeriscono modalità di utilizzo senza imporre percorsi di senso e interpretazioni rigide, per una vera libertà sostenibile.

99

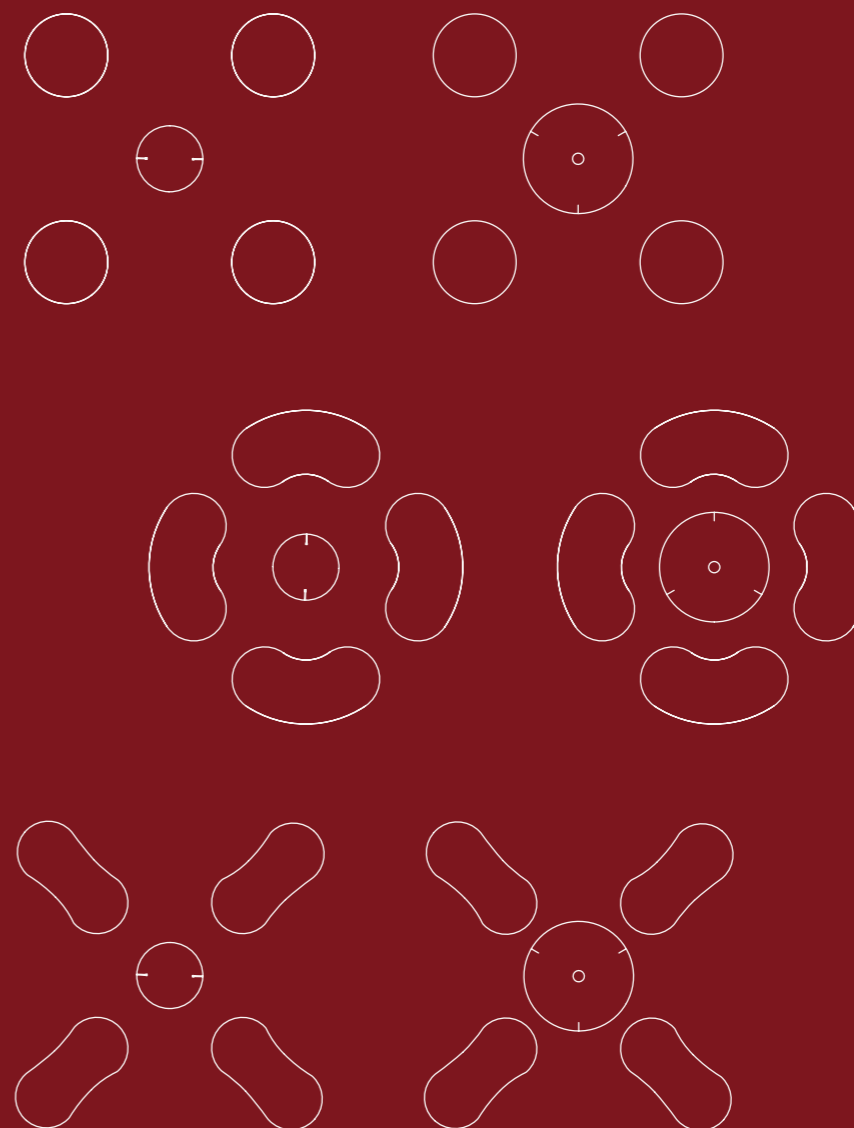

PRODUCT FACT SHEET SCHEDA PRODOTTO

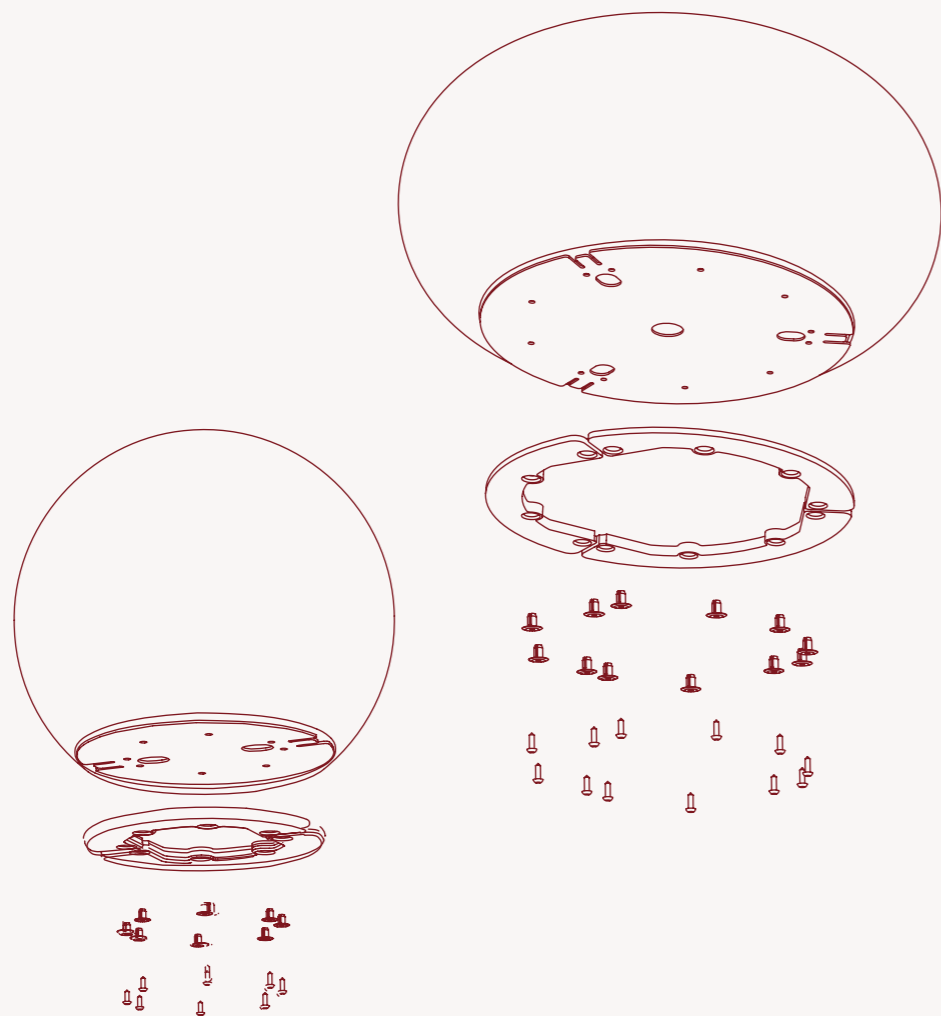

Dimensions Dimensioni

ED860

Seating and footrest/
Seduta e poggiatesta

Length/
Lunghezza: 47 cm
Depth/
Profondità: 47 cm
Height/
Altezza: 42 cm



ED870

Seating and footrest/
Seduta e poggiatesta

Length/
Lunghezza: 78 cm
Depth/
Profondità: 78 cm
Height/
Altezza: 38 cm



EB871

Seating and footrest/
Seduta e poggiatesta

Length/
Lunghezza: 92 cm
Depth/
Profondità: 46 cm
Height/
Altezza: 42 cm



EB872

Seating and footrest/
Seduta e poggiatesta

Length/
Lunghezza: 105 cm
Depth/
Profondità: 55 cm
Height/
Altezza: 42 cm

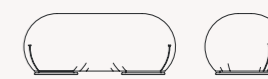

EB880

Seating and footrest/
Seduta e poggiatesta

Length/
Lunghezza: 59 cm
Depth/
Profondità: 59 cm
Height/
Altezza: 20 cm



100

101

Technical description

Elastic seat/footrest, made of flexible, cold-foamed polyurethane.

Rigid internal structure of polystyrene foam.

Elastomer bottom.

Two or three side cuts collect the removable bi-elastic fabric cover, available in two types of fabric and various colors.

Descrizione tecnica

Seduta elastica/poggiatesta, realizzato in poliuretano flessibile, schiumato a freddo.

Struttura interna rigida in polistirene espanso.

Fondo in elastomero.

Due o tre tagli laterali raccolgono il rivestimento sfoderabile in tessuto bi-elastico, disponibile in due tipologie di tessuto e vari colori.



Luigi Baroli

Born in Corbetta, in the province of Milan.

After graduating in architecture from the Milan Polytechnic, he specialized in architecture, furnishings, important events, communication and jewellery design. He has been responsible for the coordinated image, from logo development to store design, of a clothing brand. He designed furniture, handles and lamps for various companies, focusing on careful technological research and a discreet and consistent image. In 1994 he was awarded the Compasso d'Oro for the design of the Cartoons screen (to this day part of the permanent collection at the MoMa in New York and other prestigious museums) created by Baleri Italia, a company with which he has collaborated from 1988 to 2004, overseeing the artistic direction of the showroom in Milan, as well as the presentations of the collections in Italy and abroad.

His character finds faithful representation in the words of Leone Belotti who writes: «Luigi Baroli is not an archistar guru and he is not a mainstream designer, rather he is the kind of court architect, master of ceremonies, grand chamberlain who is dedicated to a brand or an enterprise and oversees the entire corporate universe like a modern Richelieu or Mazarin, standing behind the scenes but controlling everything, and in fact ruling the kingdom for the Sun King on duty, who embodies and represents the image of power, while the cardinal is its substance. [...] With Luigi Baroli you have the opportunity to talk about what goes on behind the scenes, how a brand mythology is really created».

Nasce a Corbetta, in provincia di Milano.

Dopo la laurea in architettura al Politecnico di Milano, si occupa di architettura, arredamento, importanti allestimenti, comunicazione e design del gioiello. Ha curato l'immagine coordinata, dall'elaborazione del logo fino alla progettazione dei negozi, di un brand di abbigliamento. Progetta per diverse aziende mobili, maniglie e lampade, accomunati da un'attenta ricerca tecnologica e da un'immagine discreta e coerente. Nel 1994 gli viene assegnato il Compasso d'Oro per il progetto del paravento Cartoons (ad oggi parte della collezione permanente al MoMa di New York e di altri prestigiosi musei) realizzata da Baleri Italia, azienda con la quale ha collaborato dal 1988 al 2004 curando la direzione artistica dello showroom di Milano e gli allestimenti della collezione in Italia e all'estero.

La sua persona trova fedele rappresentazione nelle parole di Leone Belotti che scrive: «Luigi Baroli non è l'archistar guru e non è il designer mainstream, piuttosto è quel tipo di architetto di corte, maestro di cerimonia, gran ciambellano che si dedica a un marchio o a un'impresa e sovrintende a tutto l'universo azienda come un moderno Richelieu o un Mazzarino, stando dietro le quinte ma controllando tutto, e di fatto governando il regno per il Re Sole di turno, che incarna e rappresenta l'immagine del potere, mentre il cardinale ne è la sostanza. [...] Con Luigi Baroli si ha l'occasione di parlare di quello che accade dietro le quinte, di come si crea realmente una mitologia di marca».



Cartoons, design Luigi Baroli



**Luigi Baroli
1992**

Cartoons is a corrugated cardboard screen made from pure cellulose. Available in white, havana, olive green, ruby red.

Cartoons is made from pure cellulose, fully recyclable. Crafted from corrugated cardboard, a humble yet reliable material, it is processed with cutting-edge technologies to ensure flexibility and adaptability. Self-supporting and rollable, the sheets come together in perfect balance. Cartoons is a minimalist architectural element, essential yet expressive: a wall that is not a wall, separating without hindering freedom of movement. Sustainable and mindful, yet free and lightweight.

Designed by Luigi Baroli in 1992, it received the Compasso d'Oro award.

Cartoons è un paravento in cartone ondulato, ricavato da pura cellulosa. Disponibile nei colori bianco, avana, verde oliva, rosso rubino.

Cartoons nasce da pura cellulosa, completamente riciclabile. Realizzato in cartone ondulato, un materiale umile ma affidabile, è lavorato con tecnologie all'avanguardia per garantire flessibilità e adattabilità. Autoportanti e arrotolabili, i fogli si incontrano in un equilibrio perfetto. Cartoons è un elemento architettonico minimalista, essenziale ma espressivo: un muro che non è muro, elemento che separa senza ostacolare la libertà di movimento. Sostenibile, consapevole, eppure libero e leggero.

Disegnato da Luigi Baroli nel 1992, ha ricevuto il premio Compasso d'Oro.



PRODUCT FACT SHEET SCHEDA PRODOTTO

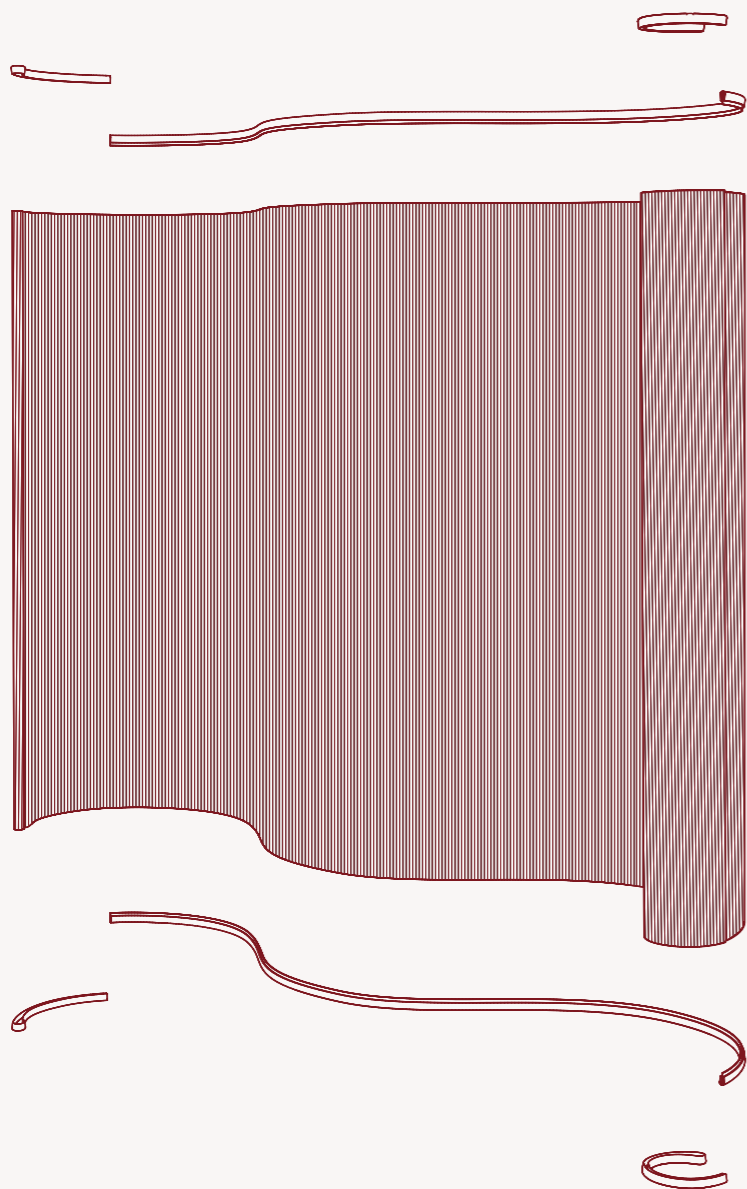

106

Dimensions Dimensioni

LB901

Screen/
Paravento

Folded/
Arrotolato: 40 cm
Max. extension/
Estensione max.: 300 cm
Height/
Altezza: 172 cm

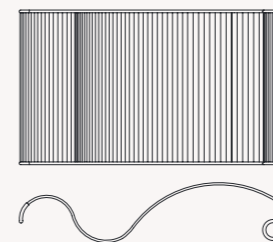

LB902

Screen/
Paravento

Folded/
Arrotolato: 40 cm
Max. extension/
Estensione max.: 220 cm
Height/
Altezza: 152 cm

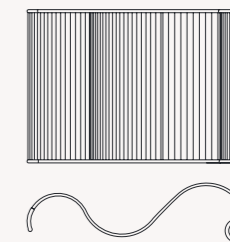

Finishes Finiture

Structure
Struttura



W - White/Bianco



H - Havana/Avana



RR - Ral 3003



VO - Ral 6003

107

Technical description

Screen with free-standing structure in corrugated cardboard extracted from pure cellulose.

Available in two configurations: H 170 cm with 40÷300 cm extension, or H 150 cm with 40÷220 cm extension.

White, havana, olive green, ruby red colors available. Customer's choice of color on request.

Upper and lower edge in matt black technopolymer.

Terminal stiffening components in brushed die-cast aluminium.

Descrizione tecnica

Paravento autoportante in cartone ondulato, ricavato da pura cellulosa totalmente riciclabile e priva di residui inquinanti.

Disponibile in due configurazioni: H 170 cm con estensione 40÷300 cm, oppure H 150 cm con estensione 40÷220 cm.

Colori bianco, avana, verde oliva, rosso rubino. Colore a scelta cliente, su richiesta.

Bordo superiore e inferiore in tecnopolimero nel colore nero opaco.

Elementi terminali di irrigidimento in alluminio pressofuso satinato.

DESIGNER



Claesson Koivisto Rune

The Swedish architecture studio Claesson Koivisto Rune was founded in 1995 by Mårten Claesson, Eero Koivisto and Ola Rune. Today, it is an internationally renowned practice, working with both architecture and design, with clients in all corners of the world.

The first Swedish firm to exhibit in the international section of the Venice Architecture Biennale, 2004, Claesson Koivisto Rune has received an array of international awards, amongst them Red Dot Design Award – Best of the Best 2024, 2014 and 2013; Designer of the Year 2014 by Elle Decor Italia; Interior Designer of the Year 2021 by Elle Deco Japan; 'Best Hotel Conversion' for K5 hotel, Tokyo, in the Asia Ahead awards 2021.

In 2021, King of Sweden Carl XVI Gustaf presented Mårten Claesson, Eero Koivisto and Ola Rune with The Prince Eugen Medal for outstanding artistic achievement in architecture (2020). They have also been the recipients of the Bruno Mathsson Award (2015), the highest honour in furniture design in Sweden and the Scandinavian region.

Lo studio di architettura svedese Claesson Koivisto Rune è stato fondato nel 1995 da Mårten Claesson, Eero Koivisto e Ola Rune. Oggi è uno studio di fama internazionale che si occupa di architettura e design, con clienti ovunque nel mondo.

Primo studio svedese a esporre nella sezione internazionale della Biennale di Architettura di Venezia nel 2004, Claesson Koivisto Rune ha ricevuto una serie di premi internazionali, tra cui il Red Dot Design Award - Best of the Best 2024, 2014 e 2013; Designer dell'anno 2014 da Elle Decor Italia; Interior Designer dell'anno 2021 da Elle Deco Japan; "Best Hotel Conversion" per l'hotel K5, Tokyo, nell'ambito degli Asia Ahead awards 2021.

Nel 2021, il re di Svezia Carl XVI Gustaf ha consegnato a Mårten Claesson, Eero Koivisto e Ola Rune la Medaglia del Principe Eugen per gli eccezionali risultati artistici in architettura (2020). Sono stati inoltre insigniti del Premio Bruno Mathsson (2015), la più alta onorificenza per il design del mobile in Svezia e nella regione scandinava.



Roundel, design Claesson Koivisto Rune



Bermuda, design Claesson Koivisto Rune



Miss Match, design Claesson Koivisto Rune

BERMUDA



110



111

Claesson Koivisto Rune 2020

Bermuda is a triangular-shaped armchair with a three-leg steel base and customisable upholstery.

A lounge chair with an original triangular structure, supported by a light three-legged base, designed for a fresh take on relaxation. Its unconventional shape and rounded edges allow Bermuda to fit seamlessly into any space, including corners, adding character to the environment. The spacious seat cushion and low, curved sides provide generous support, naturally adapting to individual preferences. A chair designed to last, crafted for genuine comfort.

Bermuda è una poltrona dalla forma triangolare, con base a tre gambe in acciaio e rivestimento personalizzabile.

Una lounge chair dall'originale struttura triangolare, sorretta da una base leggera a tre gambe, progettata per una nuova interpretazione del relax. La forma non convenzionale e i profili arrotondati permettono a Bermuda di inserirsi facilmente in qualsiasi spazio, inclusi gli angoli, aggiungendo carattere all'ambiente. L'ampio cuscino di seduta e i fianchi bassi incurvati offrono un sostegno generoso, adattandosi naturalmente alle preferenze individuali. Una sedia progettata per durare, concepita per un comfort autentico.

PRODUCT FACT SHEET SCHEDA PRODOTTO

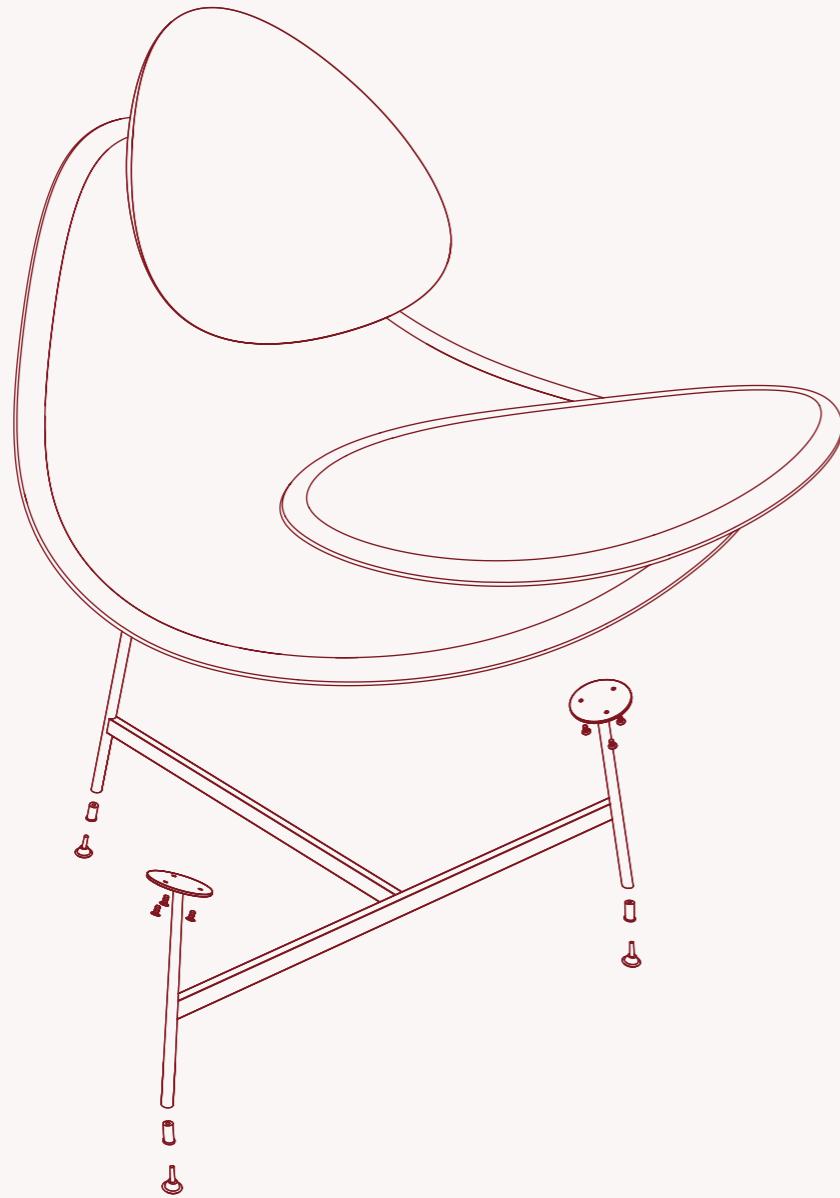

112

Dimensions Dimensioni

CKR310

Lounge chair/
Poltrona lounge

Length/
Lunghezza: 123 cm
Depth/
Profondità: 95 cm
Height/
Altezza: 88 cm

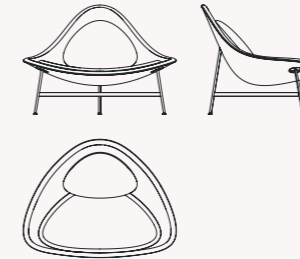

Finishes Finiture

Structure
Struttura



AM - Ral 9006



N - Ral 9005

113

Technical description

Lounge armchair with tubular steel frame painted with epoxy powders in the specified colours.

Structural rigid polyurethane inner shell overmolded with cold-foamed flexible polyurethane.

Non-removable cover in fabric, technical fabric, leather, eco-leather, customer leather (pc) or customer fabric (tc).

Descrizione tecnica

Poltrona lounge con struttura in tubo di acciaio verniciato con polveri epossidiche nei colori indicati.

Scocca interna in poliuretano rigido strutturale sovrastampato con poliuretano flessibile schiumato a freddo.

Rivestimento non sfoderabile in tessuto, tessuto tecnico, pelle, eco-pelle, pelle cliente (pc) o tessuto cliente (tc).

ROUNDEL

114



Claesson Koivisto Rune 2018

Roundel is a round table with a central base with a glossy lacquered finish in red, white or black. The backpainted glass top features concentric circles in the same colours, in three different tones.

Roundel celebrates the eternal perfection of the circle, taking its form to multiple levels. The round top, divided into three distinct discs available in different colors, suggests three zones of use, adding a functional chromatic element to the geometric purity. Sculptural and almost artisanal in its presence, Roundel embodies a democratic and egalitarian vision of the world: the round table eliminates hierarchies, encouraging direct and open eye contact among all those present.

Roundel è un tavolo rotondo con base centrale con finitura laccata lucida in rosso, bianco o nero. Il piano in cristallo retroverniciato presenta cerchi concentrici degli stessi colori, in tre toni differenti.

Roundel celebra la perfezione eterna del cerchio, riprendendone la forma a più livelli. Il piano rotondo, suddiviso in tre dischi distinti realizzabili in colori diversi, suggerisce altrettante zone di utilizzo, aggiungendo un elemento cromatico funzionale alla purezza geometrica. Scultoreo e quasi artigianale nella sua presenza, Roundel incarna una visione democratica e paritaria del mondo: il tavolo rotondo annulla le gerarchie, favorendo un contatto visivo diretto e aperto tra tutti i presenti.

115

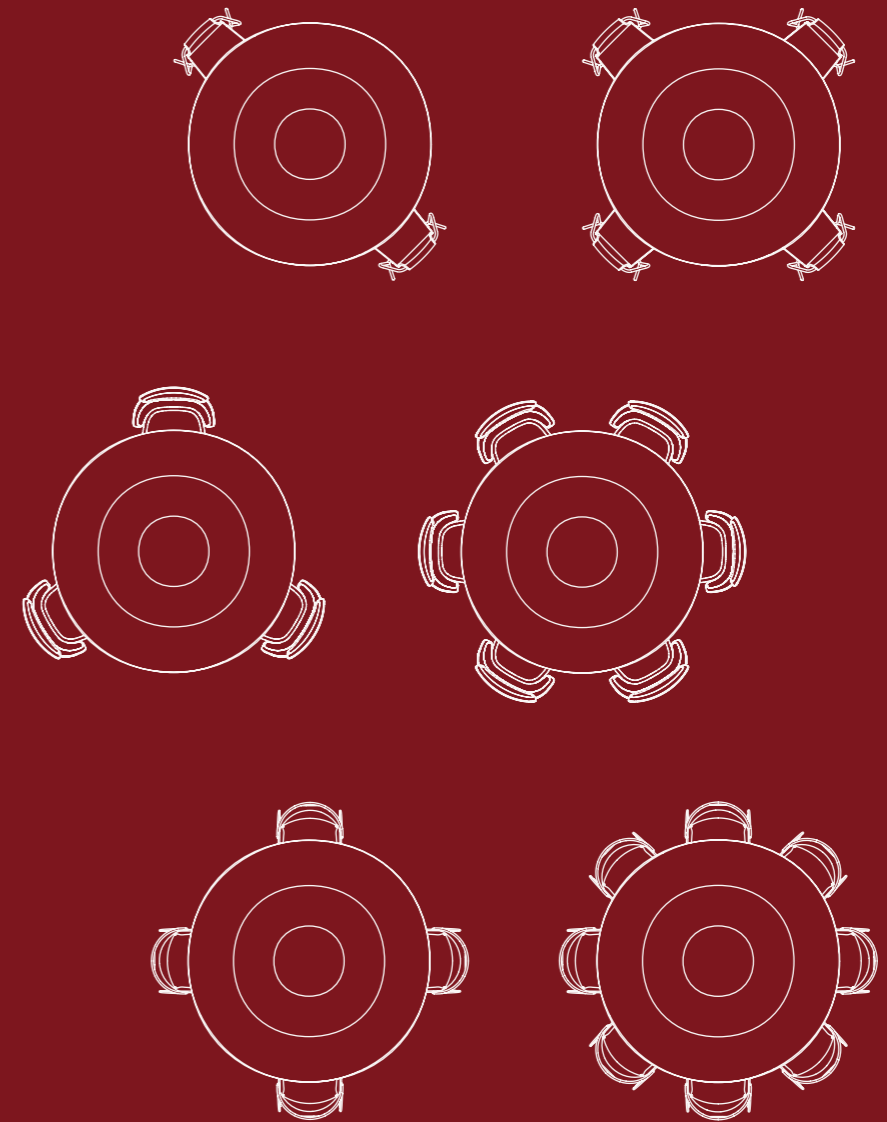

PRODUCT FACT SHEET SCHEDA PRODOTTO

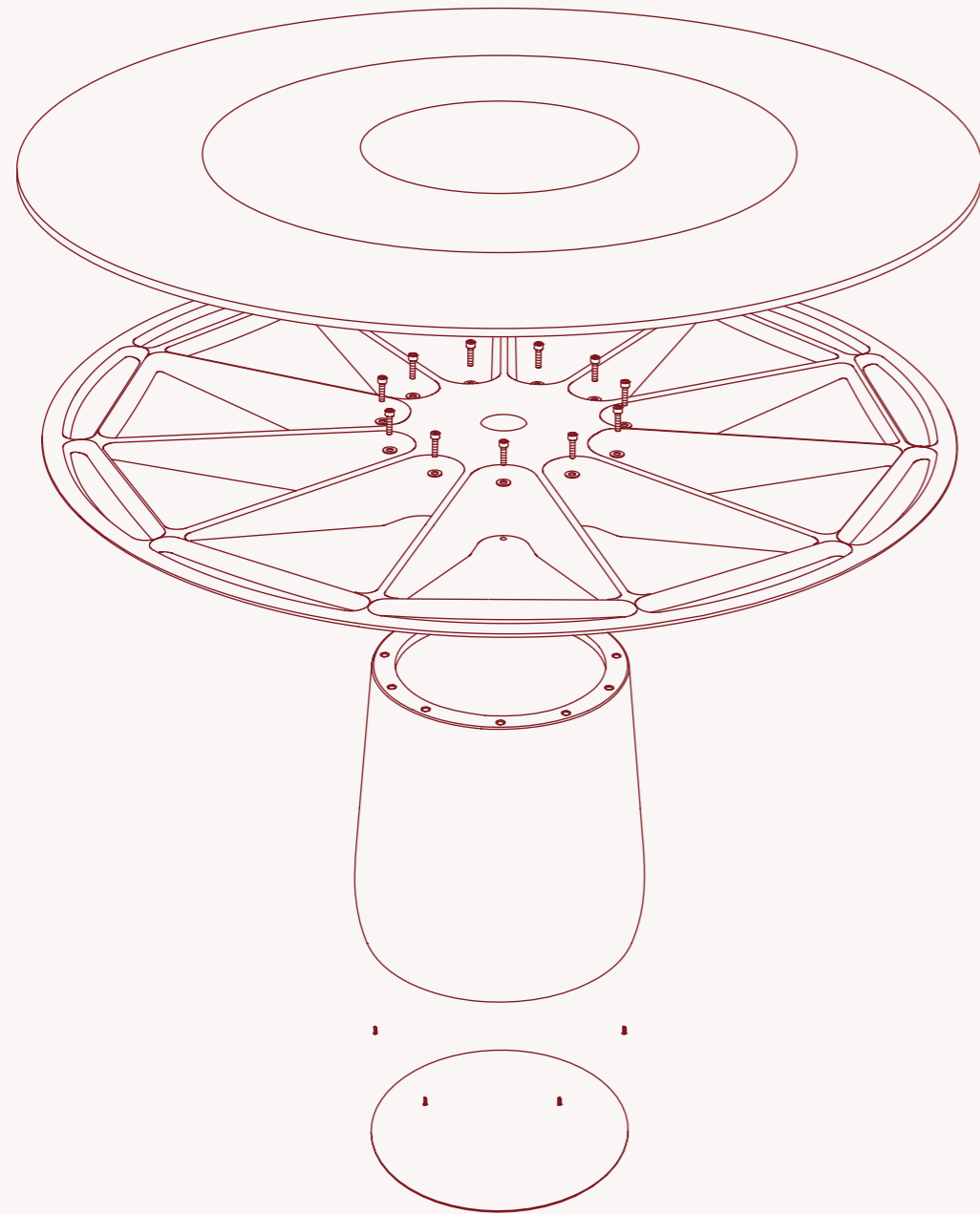

116

Dimensions Dimensioni

CKR310

Round table/
Tavolo rotondo

Diameter/
Diametro: 161 cm
Height/
Altezza: 74 cm

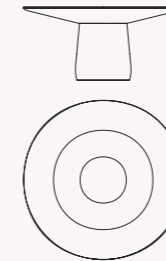

Finishes Finiture

Structure
Struttura



W - White/Bianco

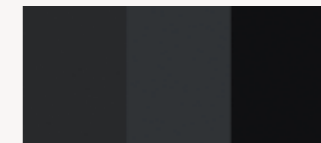

N - Black/Nero



R - Red/Rosso

117

Technical description

Round table with central base.

Structure of the under-top and central base made of structural rigid polyurethane, with either a polished red, white or black lacquered finish.

The table top is made of extra clear tempered glass backpainted with concentric red, white or black circles.

Descrizione tecnica

Tavolo tondo con base centrale.

Struttura del sottopiano e della base centrale in poliuretano rigido strutturale, realizzati nelle finiture laccato lucido rosso, bianco o nero.

Il piano del tavolo è realizzato in cristallo temperato extra chiaro retroverniciato a cerchi concentrici rossi, bianchi o neri in tre toni di colore.

MISS MATCH



118

Claesson Koivisto Rune 2018

Miss Match is a modular sofa consisting of seven configurable elements, with backrests of different heights and depths. Available with fabric, leather, eco-leather or customisable upholstery, it has completely removable covers in the fabric version.

Miss Match is a sofa conceived as a union of simple blocks, characterized by a subtle irregularity in the dimensions of the backrests, which vary slightly in height and depth, while the seats remain constant. The six seating elements can be combined in multiple configurations, inviting exploration of endless furnishing possibilities. Thanks to these differences in the individual units, the dimensional play creates a dynamic effect, resulting in a functional and versatile product, perfect for contemporary spaces.

Miss Match è un divano modulare composto da sette elementi configurabili liberamente, con schienali di diverse altezze e profondità. Disponibile con rivestimento in tessuto, pelle, eco-pelle o personalizzabile. Completamente sfoderabile nella versione in tessuto.

Miss Match è un divano pensato come unione di semplici blocchi, caratterizzati da una sottile irregolarità nelle dimensioni degli schienali, che variano leggermente in altezza e profondità mentre i piani rimangono costanti. I sei elementi di seduta possono essere combinati in molteplici configurazioni, invitando a esplorare infinite possibilità di arredo. Grazie a queste differenze nelle singole unità, il gioco dimensionale crea un effetto dinamico, il cui risultato è un prodotto funzionale e versatile, perfetto per gli spazi contemporanei.

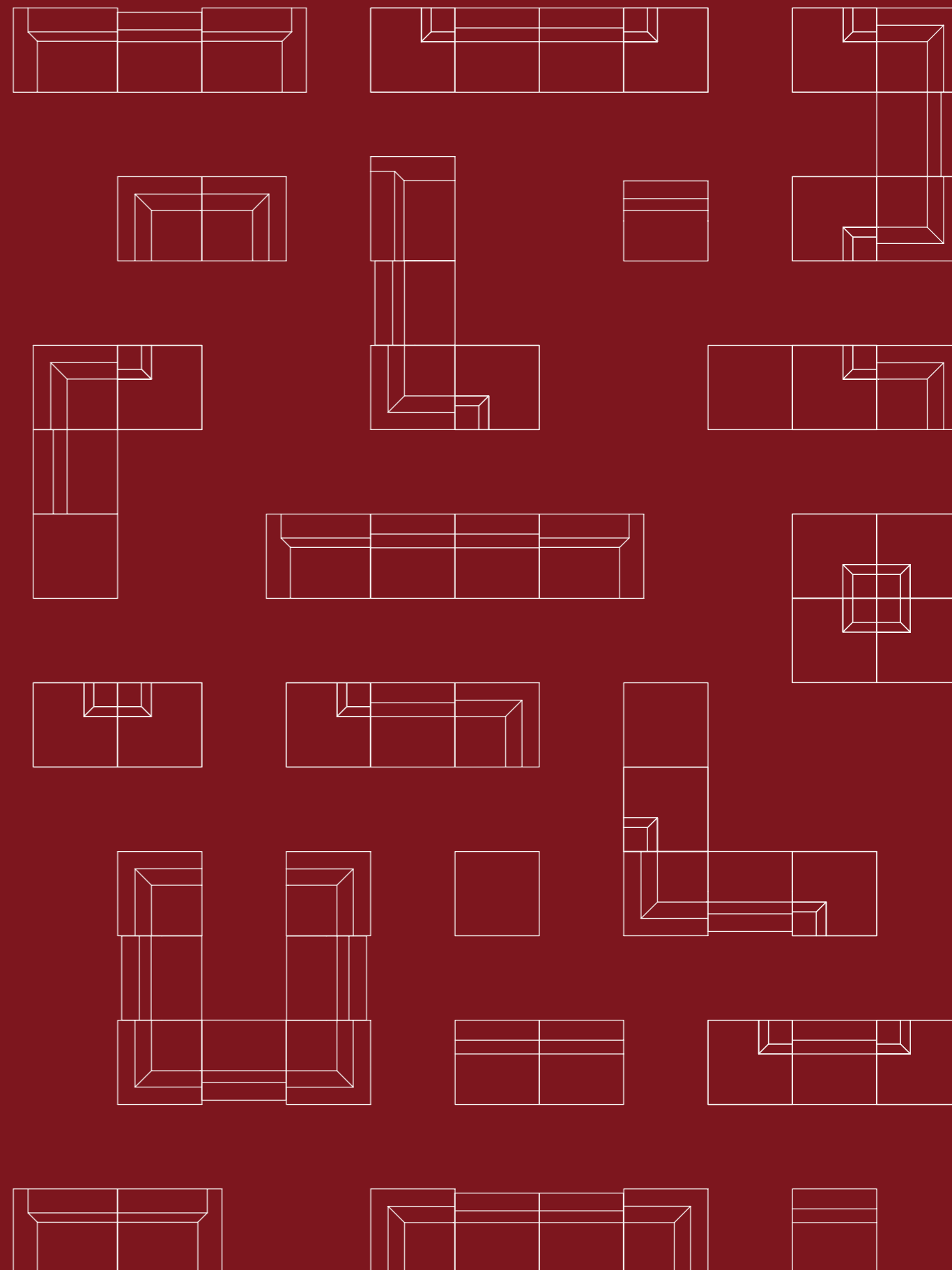

119

PRODUCT FACT SHEET SCHEDA PRODOTTO

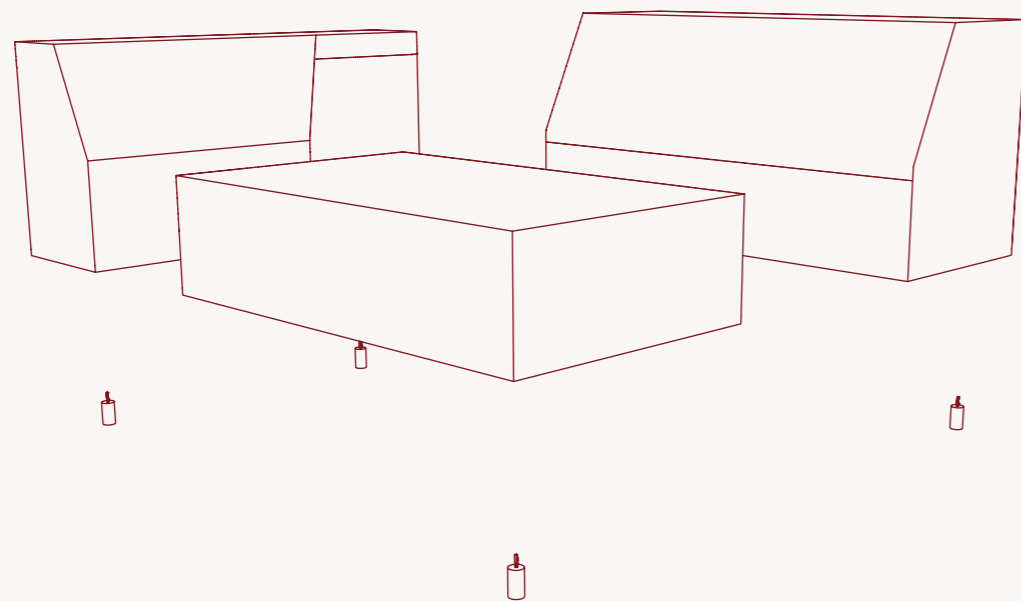

120

121

Dimensions Dimensioni

CKR301/DX-SX

Armrest end piece/
Elemento terminale bracciolo

Length/
Lunghezza: 130 cm
Depth/
Profondità: 105 cm
Height/
Altezza: 60,5 cm

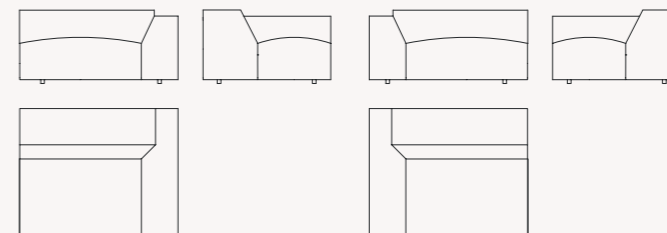

CKR302

Section without armrest S/
Elemento senza bracciolo S

Length/
Lunghezza: 100 cm
Depth/
Profondità: 95 cm
Height/
Altezza: 60,5 cm

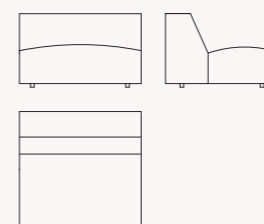

CKR303

Section without armrest L/
Elemento senza bracciolo L

Length/
Lunghezza: 100 cm
Depth/
Profondità: 100 cm
Height/
Altezza: 65 cm

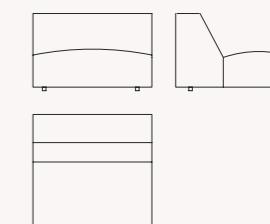

CKR304

Corner section/
Elemento angolare

Length/
Lunghezza: 100 cm
Depth/
Profondità: 100 cm
Height/
Altezza: 60,5 cm

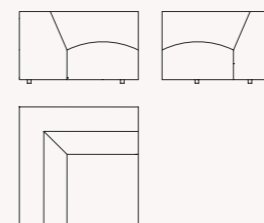

CKR305

Chill out section/
Elemento chill out

Length/
Lunghezza: 100 cm
Depth/
Profondità: 100 cm
Height/
Altezza: 55,5 cm

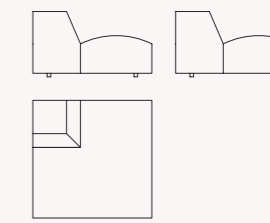

CKR306

Ottoman/
Elemento pouf

Length/
Lunghezza: 100 cm
Depth/
Profondità: 100 cm
Height/
Altezza: 35 cm

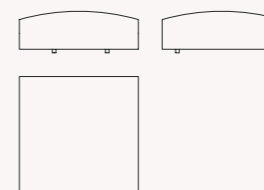

CKR300

Cushion/
Cuscino

Length/
Lunghezza: 60-56-46 cm
Depth/
Profondità: 40-36-30 cm
Height/
Altezza: 16-15-11 cm

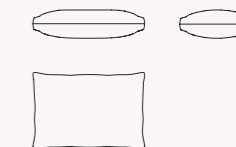

Technical description

Modular sofa composed of seven freely configurable elements with different heights and backrest depths.

Internal frame made of plywood, feet made of black powder-coated steel.

Elastic polyurethane foam and Dacron padding.

Springing by reinforced elastic straps.

Upholstery in fabric, technical fabric, leather, eco-leather, customer's leather (pc) or customer's fabric (tc); completely removable covers only in fabric version.

Descrizione tecnica

Divano modulare composto da sette elementi liberamente configurabili con differenti altezze e profondità dello schienale.

Struttura interna in legno multistrato, piedi in acciaio verniciato a polvere colore nero.

Imbottitura in poliuretano espanso elastico e dacron.

Molleggio a cinghie elastiche rinforzate.

Rivestimento in tessuto, tessuto tecnico, pelle, ecopelle, pelle cliente (pc) o tessuto cliente (tc); completamente sfoderabile solo nella versione in tessuto.

Finishes Finiture

Structure
Struttura



N - Ral 9005



Odo Fioravanti

Odo Fioravanti studied Industrial Design at the Design Department of the Milan Polytechnic. Since 1998 he has worked as an industrial designer, also experimenting graphic and exhibition design, with a firm will to melt different design areas into a continuous matter. His projects received prestigious international design awards since he created Odo Fioravanti Design Studio. He taught and lectured in many design schools and academies: Milan Polytechnic, University of Venice, San Marino University, Istituto Marangoni, Domus Academy, HEAD Genève.

His works have been featured in many international exhibitions. In 2010 the Design Museum of the Triennale di Milano featured the personal exhibition "Industrious Design" about his works. He won in 2011 the Compasso d'Oro Prize ADI with the Frida wooden chair by Pedrali. Since 2022, he has been appointed as a member of the Advisory Board of the Presidency of the School of Design of the Politecnico di Milano University. In 2023 he has been appointed Global Design Advisor for LG Electronics.

Odo Fioravanti si è laureato in Industrial Design presso la Facoltà del Design del Politecnico di Milano. Dal 1998 si occupa di industrial design, sperimentando anche la grafica e l'exhibition design, con la volontà di ricondurre le diverse discipline ad una materia continua. I suoi progetti hanno ricevuto premi prestigiosi a livello internazionale. È stato docente e lecturer presso numerose scuole e università come il Politecnico di Milano, lo IUAV di Treviso, l'Università di San Marino, l'Istituto Marangoni, la Scuola Politecnica di Design, la Domus Academy, HEAD Genève.

I suoi lavori hanno fatto parte di diverse esposizioni internazionali, culminate nel 2010 con una mostra personale dal titolo "Industrious Design" presso il Design Museum della Triennale di Milano. Nel 2011 ha vinto il Premio Compasso d'Oro ADI con la sedia in legno curvato Frida di Pedrali. Dal 2022 è stato nominato membro dell'Advisory Board della Presidenza della Scuola del Design del Politecnico di Milano. Nel 2023 è stato nominato Global Design Advisor di LG Electronics.



InBallo, design Odo Fioravanti



Spunta, design Odo Fioravanti

INBALLO

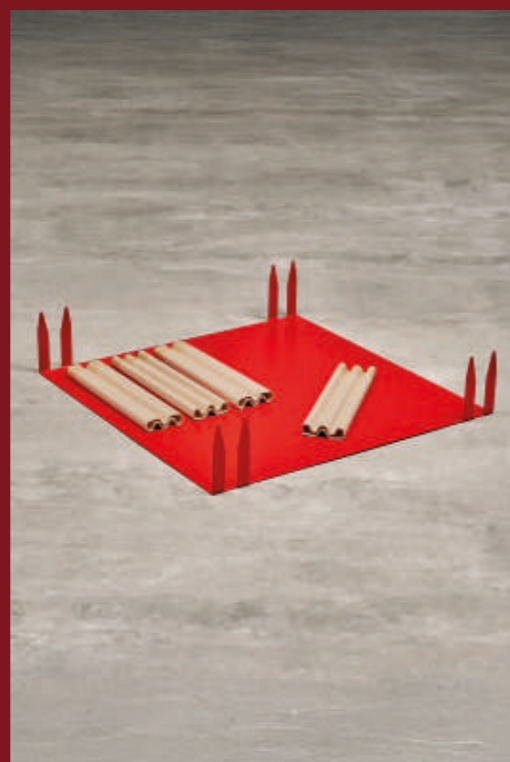

124

Odo Fioravanti 2025

The InBallo coffee tables have legs made of pure cellulose cardboard. The painted sheet metal top is available in a variety of colours. Lightweight and sustainable, it requires no tools for assembly.

The InBallo tables were born from the accidental discovery of a technology for the production of cardboard profiles used to protect and package household appliances. Inspired by their inherently sustainable nature, Odo Fioravanti transformed these extremely rigid profiles into cardboard legs connected to a metal tabletop by means of folded clamps that are inserted and anchored. The shapes of the legs, which seem to recall the classicism of ancient columns, are the result of a specific fluting of the semi-finished product, a detail that ennobles their simplicity. Designed to be shipped in reduced packaging, the tables are assembled by the end user without the use of tools, screws or glue.

InBallo è un sistema di tavolini con gambe in cartone ricavato da pura cellulosa. Il piano in lamiera verniciata è disponibile in diversi colori. Leggeri e sostenibili, non necessitano di utensili per l'assemblaggio.

I tavolini InBallo nascono per serendipità, dalla scoperta casuale di una tecnologia per la produzione di profili in cartone utilizzati per proteggere e imballare gli elettrodomestici. Ispirato dalla loro natura intrinsecamente sostenibile, Odo Fioravanti trasforma questi profili rigidissimi in gambe di cartone, connesse a un piano in metallo grazie a delle zanche piegate che si inseriscono e si ancorano. Le modanature delle gambe, che sembrano citare la classicità delle colonne antiche, sono il frutto di una grecatura propria del semilavorato, un dettaglio che ne nobilita la semplicità. Progettati per essere spediti in imballaggi ridotti, i tavolini vengono montati dall'utente finale senza utilizzare utensili, viti o colle.

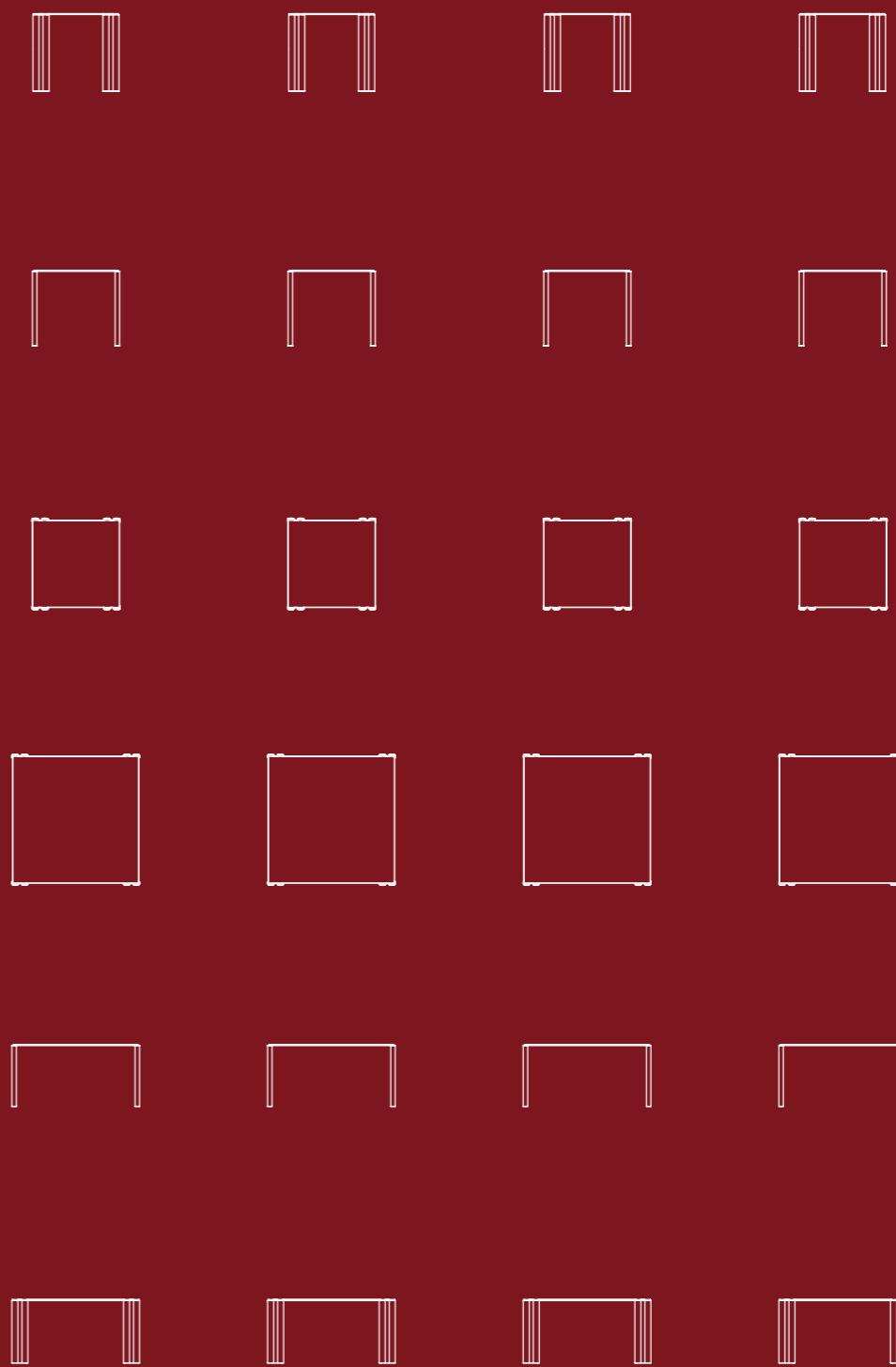

125

PRODUCT FACT SHEET SCHEDA PRODOTTO

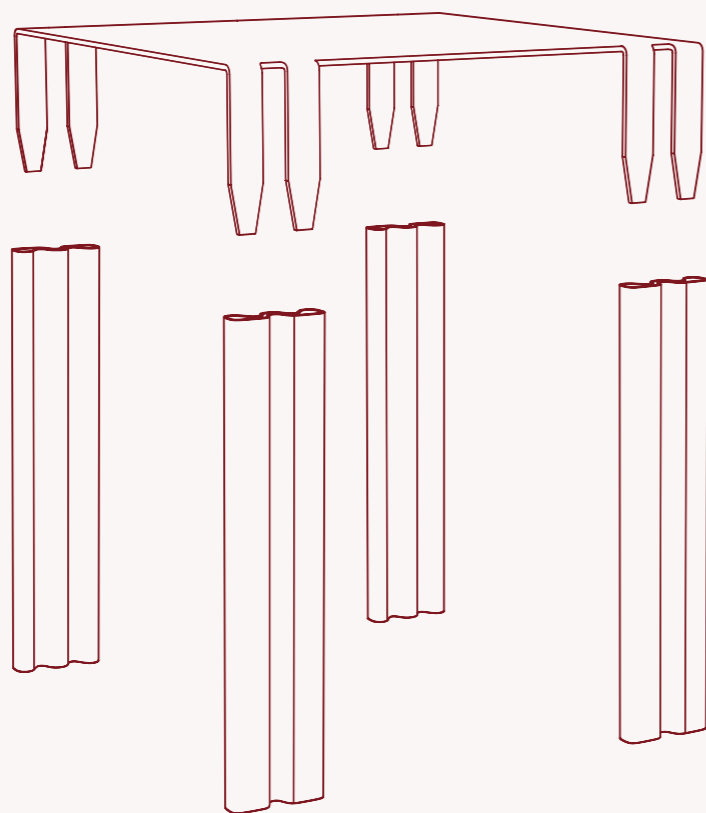

126

Technical description

Range of square low tables with press-formed sheet metal top (3 mm thick), painted with epoxy powders in the specified colours.

Free-standing cardboard legs extracted from pure cellulose, totally recyclable and free of pollutant residues, in Havana colour.

The lower end of the legs is protected by an eco-friendly, water-based transparent coating.

Legs rest on the floor with black wool felt pads.

Descrizione tecnica

Sistema di tavolini quadrati, con piano in lamiera pressopiegata (spessore 3 mm) verniciata con polveri epossidiche, nei colori indicati.

Gambe in cartone teso autoportante ricavato da pura cellulosa totalmente riciclabile e priva di residui inquinanti, in finitura avana.

La parte terminale è protetta da una finitura trasparente ecologica ad acqua.

Appoggio a terra delle gambe con protezioni in feltro di lana nero.

Dimensions Dimensioni

OF201

Square low table/
Tavolino quadrato

Length/
Lunghezza: 50 cm
Depth/
Profondità: 50 cm
Height/
Altezza: 45 cm

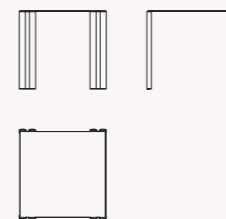

OF202

Square low table/
Tavolino quadrato

Length/
Lunghezza: 75 cm
Depth/
Profondità: 75 cm
Height/
Altezza: 37 cm

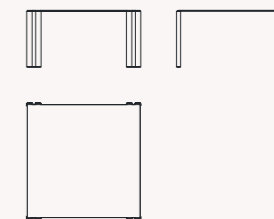

Finishes Finiture

Base
Base

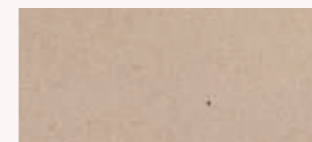

AM - Ral 9006

Top
Piano



AM - Ral 9006

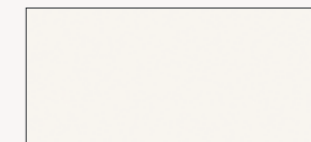

W - Ral 9010



GN - Ral 7021



N - Ral 9005

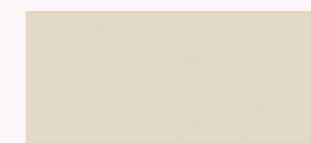

OW - Ral 1013



RR - Ral 3003



VO - Ral 6003

127

SPUNTA

128



129

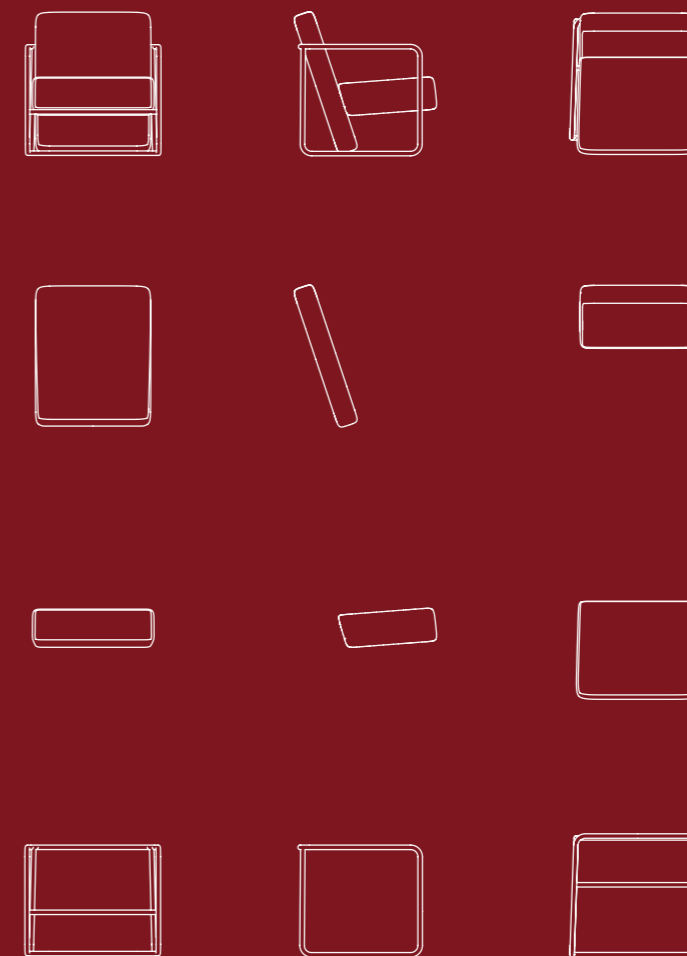

Odo Fioravanti 2025



Spunta is a small-sized armchair that can be completely disassembled. The cover is available in fabric, leather or eco-leather, or can be customised.

Designing an armchair means constantly searching for an original way to suspend in space a horizontal support cushion (the seat) and a vertical one (the backrest). Spunta armchair solves this eternal problem with two simple design gestures: extending the cushion that forms the back to the floor and suspending the seat and back in a cubic frame made up of tubes that form the armrests. The final result evokes a timeless aesthetic, that of two solids meeting in a rational cage.

Spunta è una poltrona con dimensioni ridotte, completamente disassemblabile. Il rivestimento è disponibile in tessuto, pelle o eco-pelle, oppure personalizzabile.

Disegnare una poltrona significa cercare senza sosta un modo originale per sospendere nello spazio un cuscino di appoggio orizzontale (la seduta) e uno verticale (lo schienale). La poltrona Spunta risolve questo tema eterno attraverso due gesti progettuali minimi: prolungare il cuscino che forma lo schienale fino a terra e sospendere sedile e schienale in un telaio cubico costituito da tubi che formano i braccioli. Il risultato finale evoca un'estetica senza tempo, quella di due solidi che si incontrano all'interno di una gabbia razionale.

PRODUCT FACT SHEET SCHEDA PRODOTTO

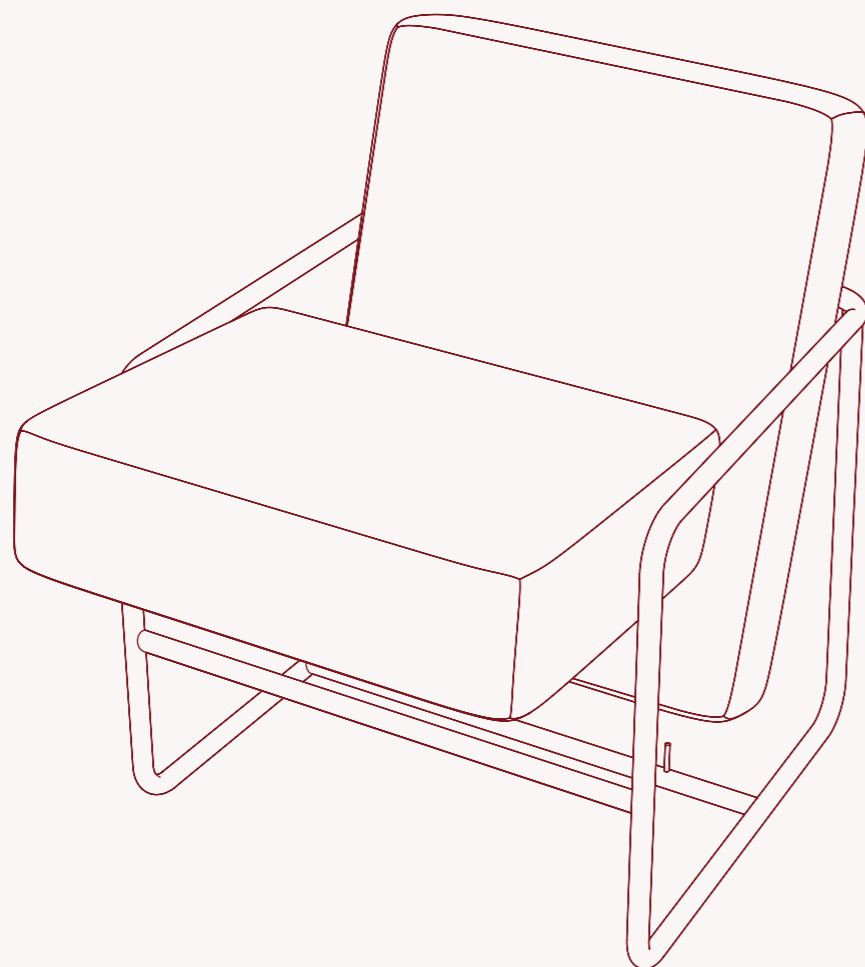

130

Dimensions Dimensioni

OF301

Armchair/
Poltrona

Length/
Lunghezza: 71 cm
Depth/
Profondità: 65 cm
Height/
Altezza: 77 cm

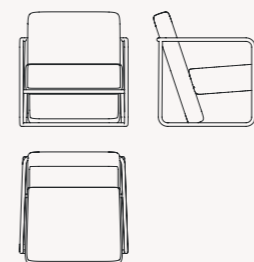

Finishes Finiture

Structure
Struttura



AM - Ral 9006

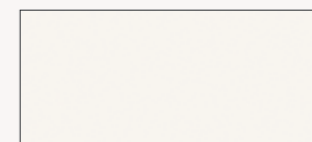

W - Ral 9010

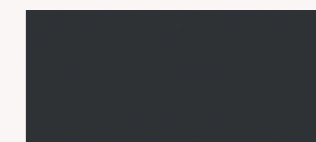

GN - Ral 7021



N - Ral 9005

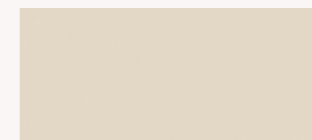

OW - Ral 1013



RR - Ral 3003



VO - Ral 6003

131

Technical description

Armchair with visible outer structure made of tubular steel profiles, painted with epoxy powders in the specified colours.

Internal structure in multilayer wood.

Elastic polyurethane foam padding of different densities.

Upholstery in fabric, technical fabric, leather, eco-leather, customer's leather (pc) or customer's fabric (tc).

Descrizione tecnica

Poltrona con struttura esterna a vista che si compone di profili tubolari in acciaio verniciati con polveri epossidiche, nei colori indicati.

Struttura interna in legno multistrato.

Imbottitura in poliuretano espanso elastico di diverse densità.

Rivestimento in tessuto, tessuto tecnico, pelle, eco-pelle, pelle cliente (pc) o tessuto cliente (tc).



132

Marialaura Irvine

Marialaura Rossiello Irvine (born in 1972) has been the creative force behind Studio Irvine for over a decade. A graduate of Architecture from Naples under the mentorship of Riccardo Dalisi, Marialaura is guided by an intrinsic respect for the narrative foundations of architecture. She began her career with a passion for traditional design before advancing to Milan to study Strategic Design at Politecnico di Milano. With marketing, communication, and strategy as focal points, she gained valuable experience collaborating with top Italian design firms, viewing products as part of a company's overall strategy.

Later, she began blending her expertise with the British design approach, working alongside her late husband, James Irvine. Her design process defies attachment to any single style or typology; it is distinguished by a meticulous methodology fueled by comprehensive research and profound historical understanding that informs each stage of the design journey. Marialaura's philosophy is akin to a radical whisper, advocating the transformative potential of materiality.

Marialaura Rossiello Irvine (nata nel 1972) è l'anima creativa dietro lo Studio Irvine da oltre un decennio. Laureata in Architettura a Napoli sotto la guida di Riccardo Dalisi, Marialaura è ispirata da un profondo rispetto per le fondamenta narrative dell'architettura. Ha iniziato la sua carriera con una passione per il design tradizionale, per poi trasferirsi a Milano per approfondire gli studi in Design Strategico al Politecnico di Milano. Con il marketing, la comunicazione e la strategia come punti focali, ha acquisito preziose esperienze collaborando con rinomati studi di design italiani, considerando i prodotti come parte integrante della strategia complessiva di un'azienda.

Successivamente, ha fuso la sua competenza con l'approccio britannico al design, collaborando con suo marito, James Irvine. Il suo processo di design sfugge all'adesione a uno stile o a una tipologia specifica; è caratterizzato da una metodologia meticolosa alimentata da una ricerca approfondita e da una profonda comprensione storica che informa ogni fase del percorso di progettazione. La filosofia di Marialaura è come un "radical whisper" (sussurro radicale) che sostiene il potenziale trasformativo della materialità.



Donna, design Marialaura Irvine

133

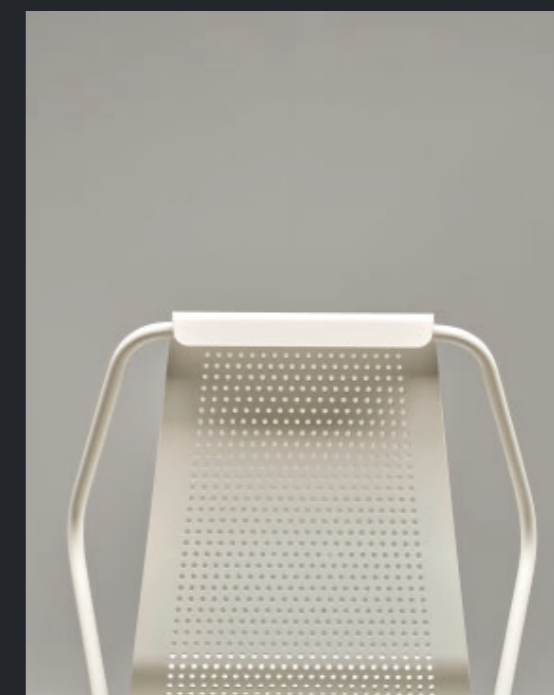

Donna, design Marialaura Irvine



Marialaura Irvine 2019

Donna is a versatile chair available in two versions. The first, stackable and recyclable, is suitable for indoor and outdoor use, featuring a stainless steel tubular frame with perforated seat and backrest, available in a variety of colours. The second is upholstered, available in all fabrics and leathers from the collection or customizable on request.

Donna is the perfect synthesis of physical lightness and expressive strength. Essential in its lines, free of embellishments, it presents a minimalist presence yet full of meaning. Easily stackable and functional, Donna naturally adapts to various spaces and uses, while maintaining its character intact. Available in a purely metallic version, which reveals its authentic essence, or in an upholstered version, enhancing its comfort, Donna embodies design as an exploration of reality, where each element becomes form and substance.



Donna è una sedia dal design versatile, proposta in due versioni. La prima, impilabile e riciclabile, è adatta ad ambienti interni ed esterni e presenta una struttura in acciaio inox con sedile e schienale traforati, disponibile in vari colori. La seconda è imbottita, realizzabile in tutti i tessuti e le pelli a catalogo o su richiesta.

Donna è la sintesi perfetta tra leggerezza fisica e forza espressiva. Essenziale nelle linee, priva di orpelli, si manifesta con una presenza minimalista eppure densa di significato. Agilmente impilabile e funzionale, Donna si adatta con naturalezza a diversi spazi e utilizzi, mantenendo intatto il suo carattere. Disponibile in una versione puramente metallica, che ne rivela l'anima autentica, o imbottita, che ne esalta il comfort, Donna racconta il design come esplorazione del reale, dove ogni elemento diviene forma e sostanza.

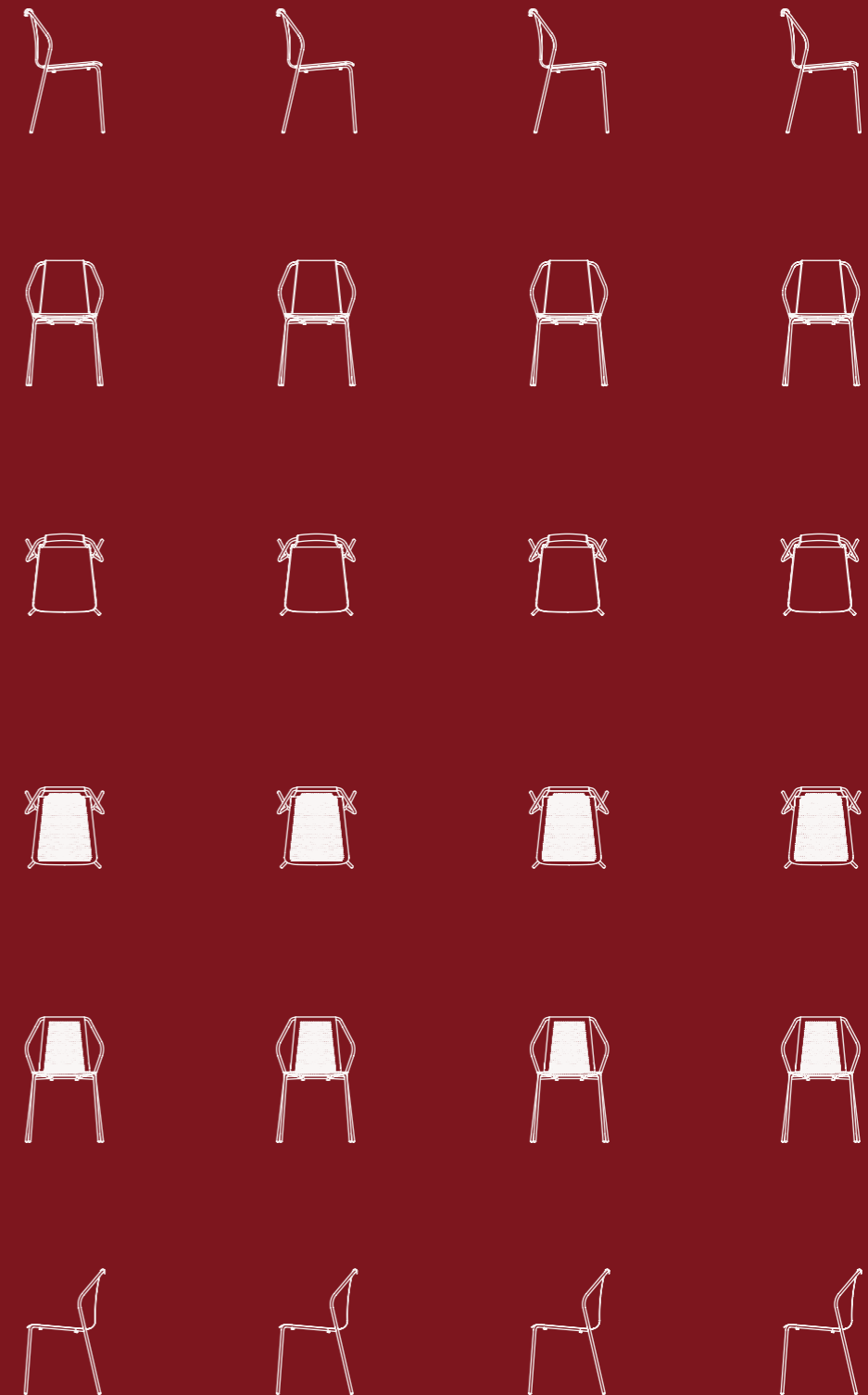

PRODUCT FACT SHEET SCHEDA PRODOTTO

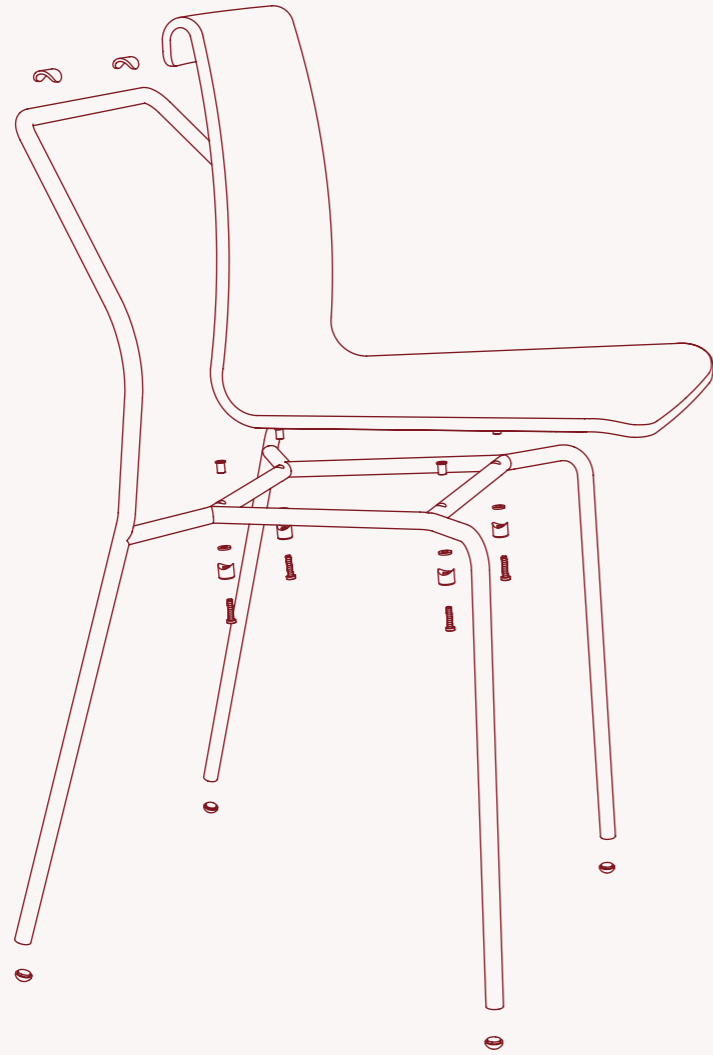

136

Dimensions Dimensioni

IR101

Stackable chair/
Sedia impilabile

Length/
Lunghezza: 50 cm
Depth/
Profondità: 50 cm
Height/
Altezza: 80 cm

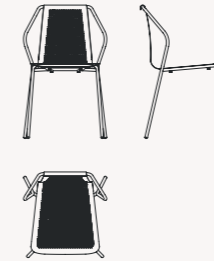

IR103

Upholstered chair/
Sedia rivestita

Length/
Lunghezza: 50 cm
Depth/
Profondità: 50 cm
Height/
Altezza: 81 cm

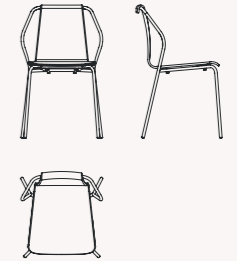

Finishes Finiture

Structure
Struttura



AM - Ral 9006

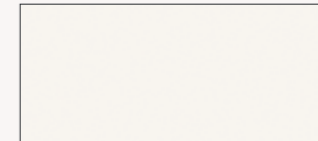

W - Ral 9010



GN - Ral 7021



N - Ral 9005

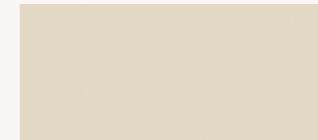

OW - Ral 1013



RR - Ral 3003



VO - Ral 6003

137

Technical description

Chair with tubular steel frame, painted with epoxy powders in the specified colours, available in two versions.

Indoor chair with seat and backrest made of flexible polyurethane foam on both sides.

Non-removable cover in fabric, technical fabric, leather, eco-leather, customer leather (pc) or customer fabric (tc).

Outdoor stackable chair with seat and back in perforated AISI 304 stainless steel sheet, painted with epoxy powders in the specified colours.

Descrizione tecnica

Sedia con struttura in tubolare di acciaio verniciata con polveri epossidiche nei colori indicati, disponibile in due varianti.

Sedia indoor con sedile/schienale in poliuretano espanso flessibile su entrambi i lati.

Rivestimento non sfoderabile, in tessuto, tessuto tecnico, pelle, eco-pelle, pelle cliente (pc) o tessuto cliente (tc).

Sedia outdoor impilabile con sedile e schienale in lamiera traforata in acciaio inox AISI 304, verniciati con polveri epossidiche nei colori indicati.

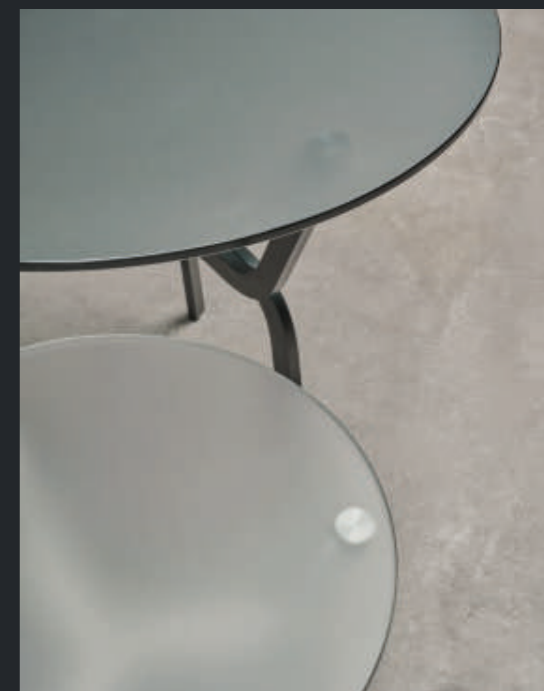

Roots, design Arik Levy

Arik Levy

138

“Creation is an uncontrolled muscle” according to Arik Levy (born 1963).

Artist, technician, photographer, designer, video artist, Levy's skills are multi-disciplinary, and his works are shown and installed worldwide. Best known publicly for his sculptures – such as his signature Rock pieces –, his installations, limited editions and design, Levy nevertheless feels “The world is about people, not objects.”

Hailing originally from Israel and moving to Europe after his first participation in a group sculpture exhibition in Tel-Aviv in 1986, Levy set up his studio in Paris in 1992.

Heavily dyslexic, art became his medium of expression. His formation was unconventional where surfing and painting on surfboards as if they were canvas, as well as his art and graphic design studio, took all his time back home. After years of practice Levy decides to take on studies at the Art Center Europe in Switzerland where he gains a BS with distinction 1991.

After a stint in Japan where he consolidates his ideas, observing Japanese minimalist culture and way of life, and taking on very different experiences such as manufacturing products and pieces for exhibitions, Levy returns to Europe where he contributes his artistry to another field – contemporary dance and opera by way of set design and installations.

The creation of his studio then meant a foray back to art, his first love, followed by industrial design, as well as other ways of expressing his talent.

Considering himself now more of a “feeling” artist, Arik Levy continues to contribute substantially to our interior and exterior milieu, his work including public sculpture, as well as complete environments that can be adapted for multi-use. “Life is a system of signs and symbols,” he says, “where nothing is quite as it seems.”

Arik Levy is Chevalier des Arts et des Lettres de la République française.

“La creazione è un muscolo senza controllo” secondo Arik Levy (1963).

Artista, tecnico, fotografo, designer, videoartista, le competenze di Levy sono multidisciplinari e le sue opere sono esposte e installate in tutto il mondo. Noto al pubblico soprattutto per le sue sculture - come i suoi pezzi Rock - le installazioni, le edizioni limitate e il design, Levy ritiene tuttavia che “il mondo è fatto di persone, non di oggetti”.

Originario di Israele e trasferitosi in Europa dopo la sua prima partecipazione a una mostra collettiva di scultura a Tel-Aviv nel 1986, Levy ha aperto il suo studio a Parigi nel 1992.

Fortemente dislessico, l'arte è diventata il suo mezzo di espressione. La formazione non convenzionale (il surf e la pittura su tavole da surf come fossero tele), e la fondazione di uno studio d'arte e di grafica lo tenevano occupato durante i primi anni, a casa. Dopo molta pratica, Levy decide di intraprendere gli studi presso l'Art Center Europe in Svizzera, dove ottiene una laurea con lode nel 1991.

Dopo un soggiorno in Giappone, luogo in cui consolida le sue idee osservando la cultura e lo stile di vita minimalista giapponese e affrontando esperienze molto diverse tra loro, come la produzione di prodotti e pezzi per mostre, Levy torna in Europa dove contribuisce con la sua arte a un altro campo, quello della danza contemporanea e dell'opera, attraverso scenografie e installazioni.

La creazione del suo studio significa un ritorno all'arte, il suo primo amore, seguito dal design industriale e da altri modi di esprimere il suo talento.

Considerandosi oggi più un artista del “sentire”, Arik Levy continua a contribuire in modo sostanziale al nostro ambiente interno ed esterno; il suo lavoro comprende sculture pubbliche e ambienti completi che possono essere adattati per un uso multiplo. “La vita è un sistema di segni e simboli”, dice, “dove nulla è come sembra”.

Arik Levy è Chevalier des Arts et des Lettres de la République française.



Roots, design Arik Levy

139

ROOTS

140



Arik Levy 2025

Roots is a collection of tables, coffee tables and bar tables with round tops and aluminium frames. The top is made of tempered glass and is available in transparent, translucent etched or smoked versions. Completely disassemblable, lightweight and optimised for transport.

The Roots Table Collection is born from nature's quiet strength, the unseen force that anchors trees, nourishes them, and gives them resilience: their roots. In the mangroves, roots weave through water and earth, breathing life into their surroundings. Inspired by this delicate yet powerful balance, Arik Levy sought to translate these principles into a table collection - one that embodies intelligence, elegance, and purpose. The base of the table is a rhythmic repetition of a single geometric form, an elemental structure that interlocks in harmony to create strength and refinement. This approach minimizes material use and transforms a single fractal-like component into an entire structure, seamlessly assembling through magnetic connections. It also reduces shipping volume and optimizes fabrication, echoing nature's efficiency in design. Roots is more than furniture - it is a sculptural dialogue between nature's organic poetry and the precision of industrial intelligence. A meeting of past and future, stability and movement, structure and soul.



Roots è una collezione di tavoli, tavolini e tavoli bar con piani rotondi e struttura in alluminio. Il piano è in cristallo temperato e disponibile in versione trasparente, acidato traslucido o fumé. Completamente disassemblabili, leggeri e ottimizzati per il trasporto.

La Roots Table Collection nasce dalla forza silenziosa della natura, una forza invisibile che ancora gli alberi, li nutre e li rende resilienti: le radici. Nelle mangrovie, le radici si intrecciano tra acqua e terra, sostenendo e dando vita all'ambiente circostante. Ispirato da questo delicato ma potente equilibrio, Arik Levy ha cercato di tradurre questi principi in una collezione di tavoli che incarni intelligenza, eleganza e significato. La base del tavolo è una ripetizione ritmica di un'unica forma geometrica, una struttura elementare che si intreccia in armonia per creare forza e raffinatezza. Questo approccio riduce al minimo l'uso di materiale e trasforma un singolo componente frattale in un'intera struttura, assemblata senza soluzione di continuità tramite connessioni magnetiche. Inoltre, riduce il volume dei colli da spedire e ottimizza la produzione. Roots è più di un elemento d'arredo: è un dialogo scultoreo tra la poesia organica della natura e la precisione dell'intelligenza industriale. Un incontro tra passato e futuro, stabilità e movimento, struttura e anima.

141

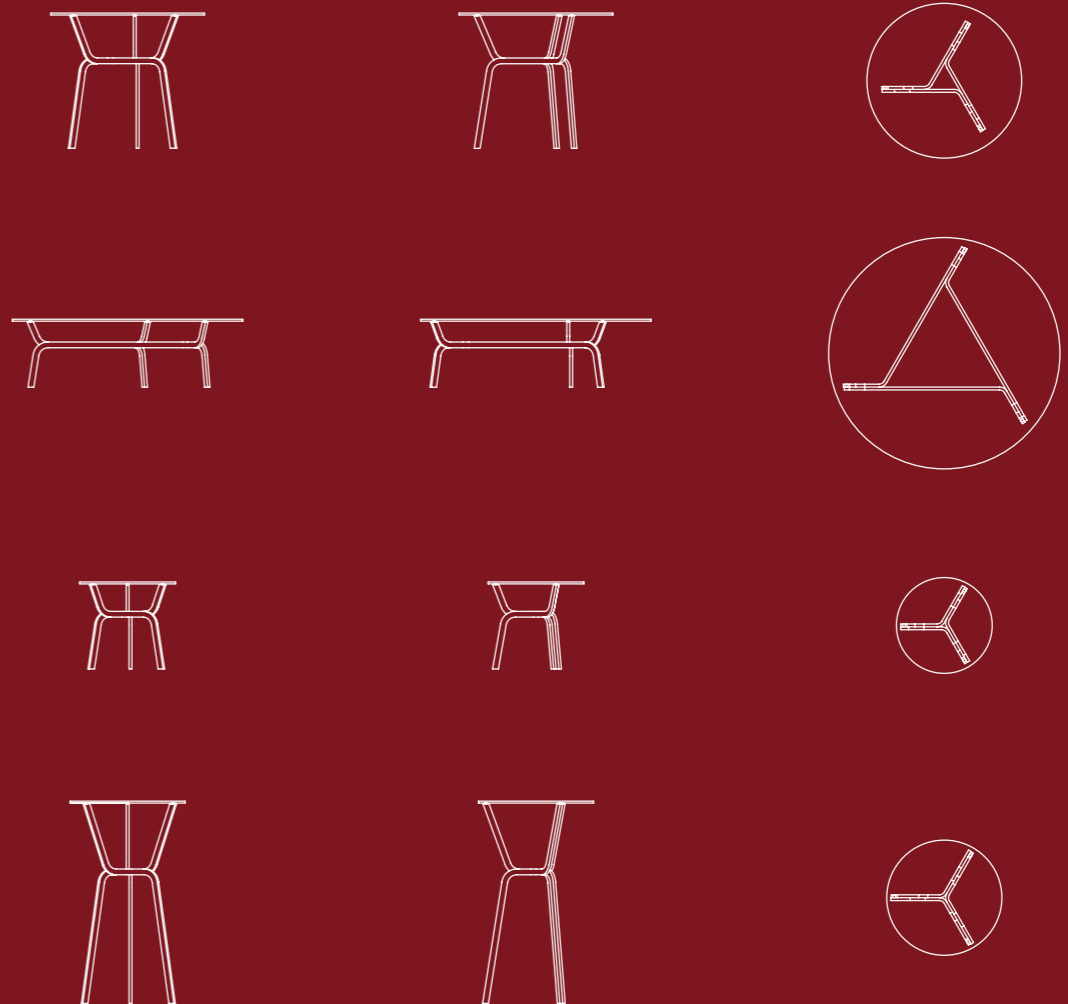

PRODUCT FACT SHEET SCHEDA PRODOTTO

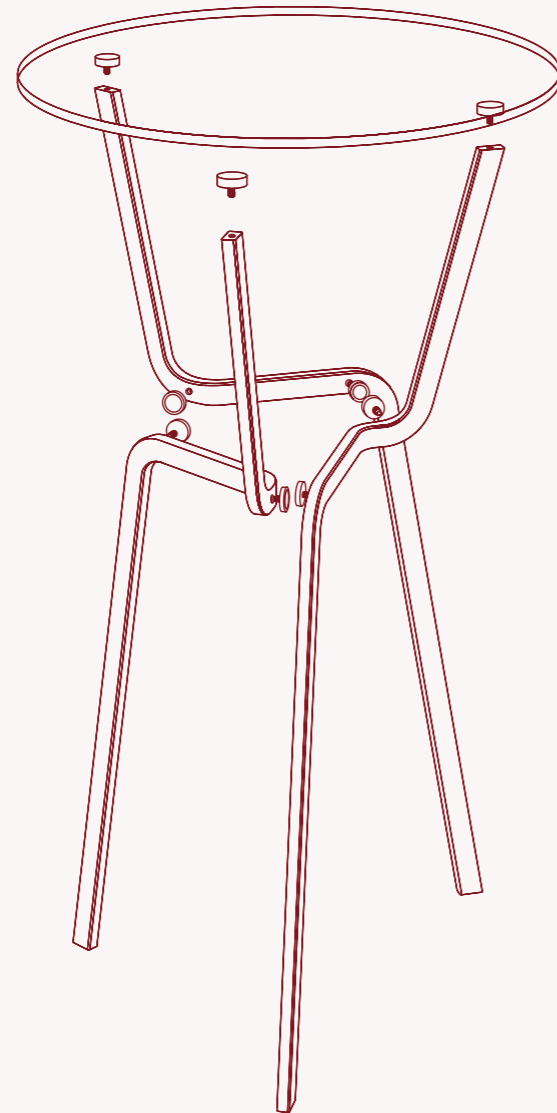

142

Technical description

Range of round reversible tables, with structure in aluminium painted with epoxy powders in the specified colours.

Magnetically connected structure, fully detachable, with locking set screw.

Top available in clear, translucent acid-etched or smoked acid-etched tempered glass (8 mm thick), with electro-welded metal discs for leg attachment via locking set screw.

Legs rest on the floor with black wool felt pads.

Descrizione tecnica

Sistema di tavoli reversibili rotondi, con struttura in alluminio verniciata con polveri epossidiche nei colori indicati.

Struttura a connessione magnetica totalmente disassemblabile con grano di sicurezza.

Piano disponibile in cristallo temperato trasparente, acidato traslucido o acidato fumé (spessore 8 mm), con dischi metallici elettrosaldati per il fissaggio alle gambe con grano di sicurezza.

Appoggio a terra delle gambe con protezioni in feltro di lana nero.

Dimensions Dimensioni

AL210

Round table/
Tavolino tondo

Diameter/
Diametro: 80 cm
Height/
Altezza: 70 cm

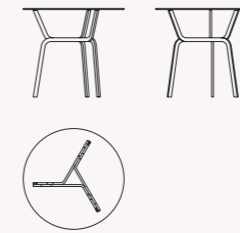

AL211

Round low table/
Tavolino tondo

Diameter/
Diametro: 120 cm
Height/
Altezza: 35 cm

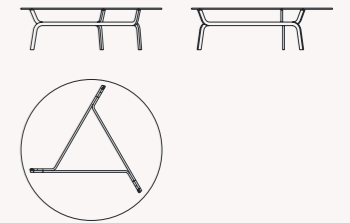

AL212

Round low table/
Tavolino tondo

Diameter/
Diametro: 50 cm
Height/
Altezza: 45 cm

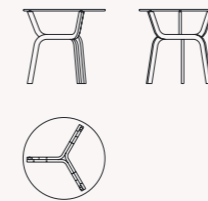

AL213

Round bar table/
Tavolo tondo bar

Diameter/
Diametro: 60 cm
Height/
Altezza: 105 cm

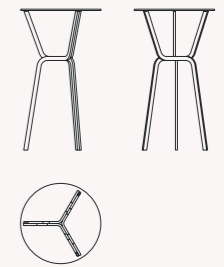

143

Finishes Finiture

Base
Base



AM - Ral 9006

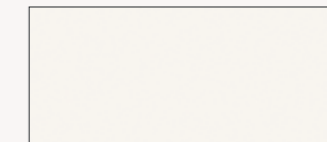

W - Ral 9010

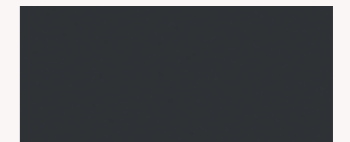

GN - Ral 7021



N - Ral 9005

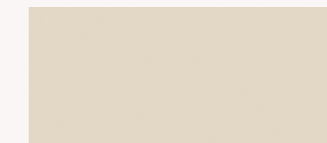

OW - Ral 1013



RR - Ral 3003



VO - Ral 6003

Top
Piano



CT
Transparent crystal/
Cristallo trasparente



CAT
Traslucent acid-etched crystal/
Cristallo acidato traslucido

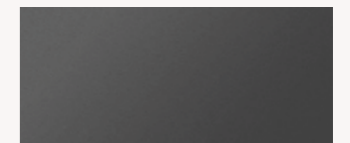

CG
Smoked acid-etched crystal/
Cristallo acidato fumé

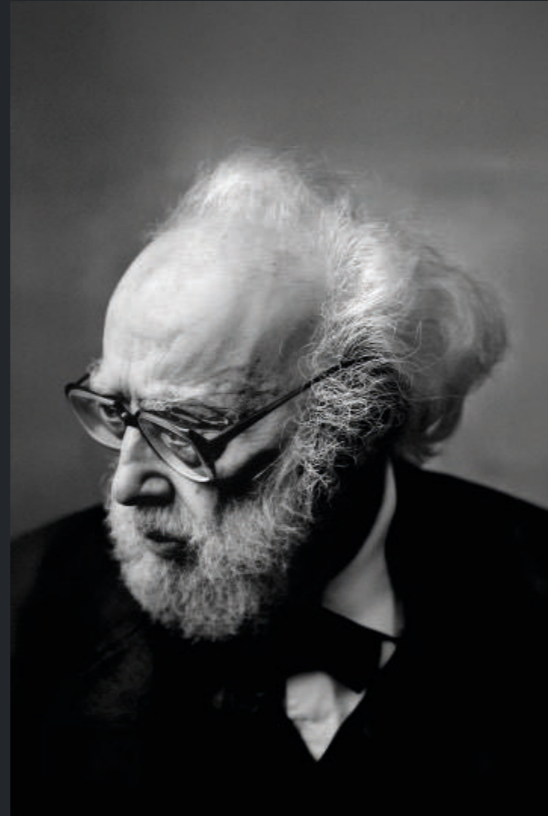

T-Table, design Angelo Mangiarotti

Angelo Mangiarotti

Angelo Mangiarotti, Milanese architect and designer, graduated from the Politecnico di Milano in 1948, leaving a significant mark on 20th-century Italian design.

Renowned for the balance between form and function, he collaborated with prestigious companies, contributing to the success of modern Italian design. Among his notable architectural works are the skyscraper in Niguarda, Milan, and the church of San Giovanni Battista in Augusta.

His minimalist approach and attention to construction precision are also reflected in furniture and everyday objects, which have become design icons. Mangiarotti was a member of the ADI (Association for Industrial Design), emphasizing his commitment to shaping the landscape of Italian industrial design.

Angelo Mangiarotti, architetto e designer milanese, laureato al Politecnico di Milano nel 1948, ha segnato il design italiano del XX secolo.

Celebre per l'equilibrio tra forma e funzione, ha collaborato con aziende prestigiose, contribuendo al successo del design italiano moderno. Tra le sue opere architettoniche spiccano il grattacielo a Niguarda, Milano, e la chiesa di San Giovanni Battista ad Augusta.

L'approccio minimalista e l'attenzione alla precisione costruttiva si riflettono anche nei mobili e oggetti d'uso quotidiano, diventati icone del design. Mangiarotti è stato membro dell'ADI (Associazione per il Disegno Industriale), sottolineando il suo impegno nel plasmare il panorama del design industriale italiano.



T-Table, design Angelo Mangiarotti

T-TABLE

146



Angelo Mangiarotti 1998/2025



T-Table is a line of tables, coffee tables and consoles with a painted aluminium structure that can be completely disassembled and recycled. Available in a variety of colours they feature a top with bevelled edges that fits flush into the structure.

An apparently simple table, yet rich in meaning. Angelo Mangiarotti resolves the contradiction between essentiality and detail through the pairing of two 'L'-shaped extrusions, which, with a 45° cut, transform into a 'T'. Thus, the table, in its utmost simplicity, as if drawn by a child, becomes a visually refined and suspended object, maintaining a solid and light structure.

T-Table è una linea di tavoli, tavolini e consolle, con struttura in alluminio verniciato, completamente disassemblabile e riciclabile. Disponibile in diversi colori, ha un piano con bordi smussati inserito a filo nella struttura.

Un tavolo apparentemente semplice ma denso di significati. Angelo Mangiarotti risolve la contraddizione tra essenzialità e dettaglio attraverso l'accostamento di due estrusi a "L" che, con un taglio a 45°, si trasformano in "T". Così il tavolo, nella sua massima semplicità, come disegnato da un bambino, diventa un oggetto visivamente raffinato e sospeso, mantenendo una struttura solida e leggera.

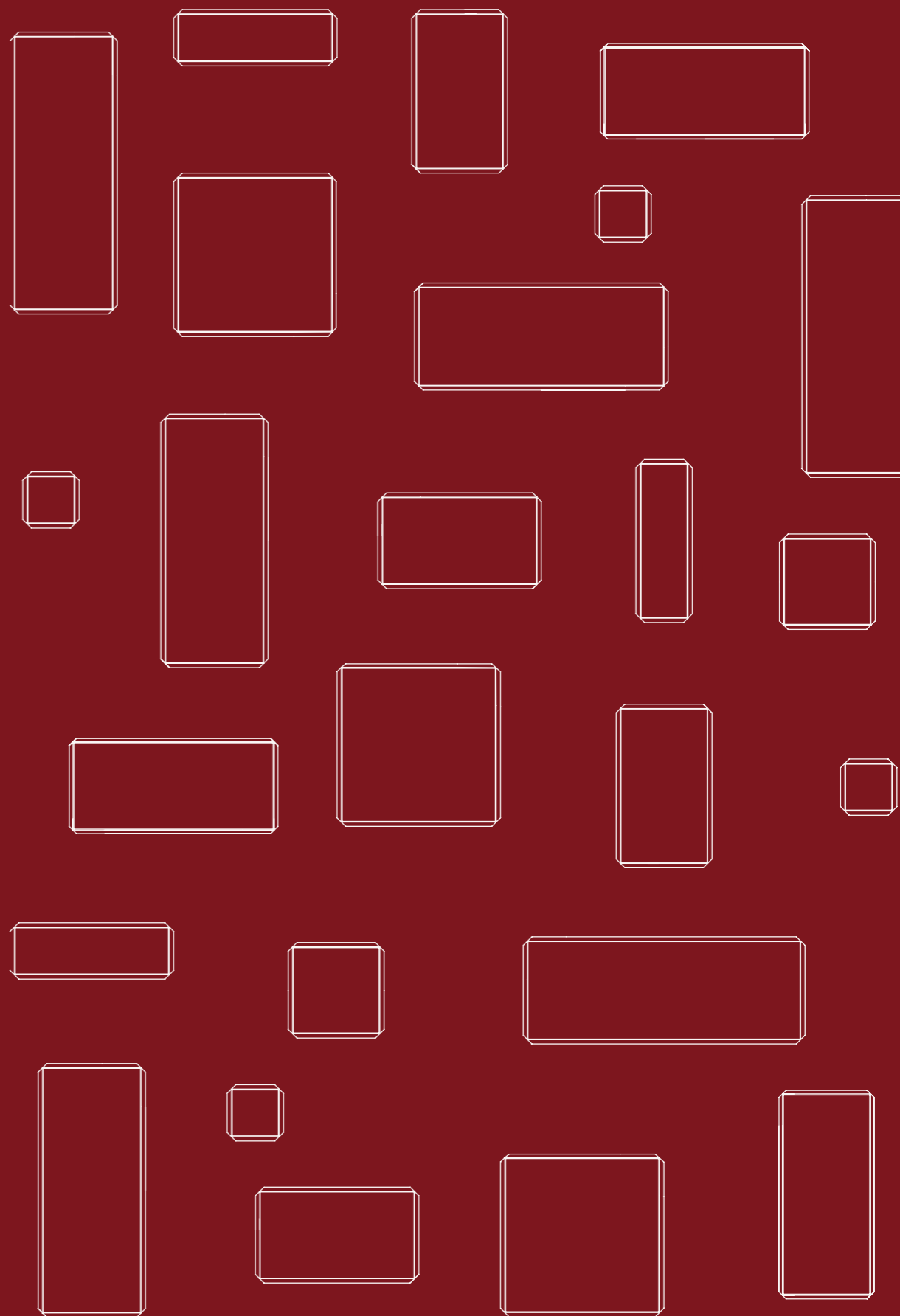

147

PRODUCT FACT SHEET SCHEDA PRODOTTO

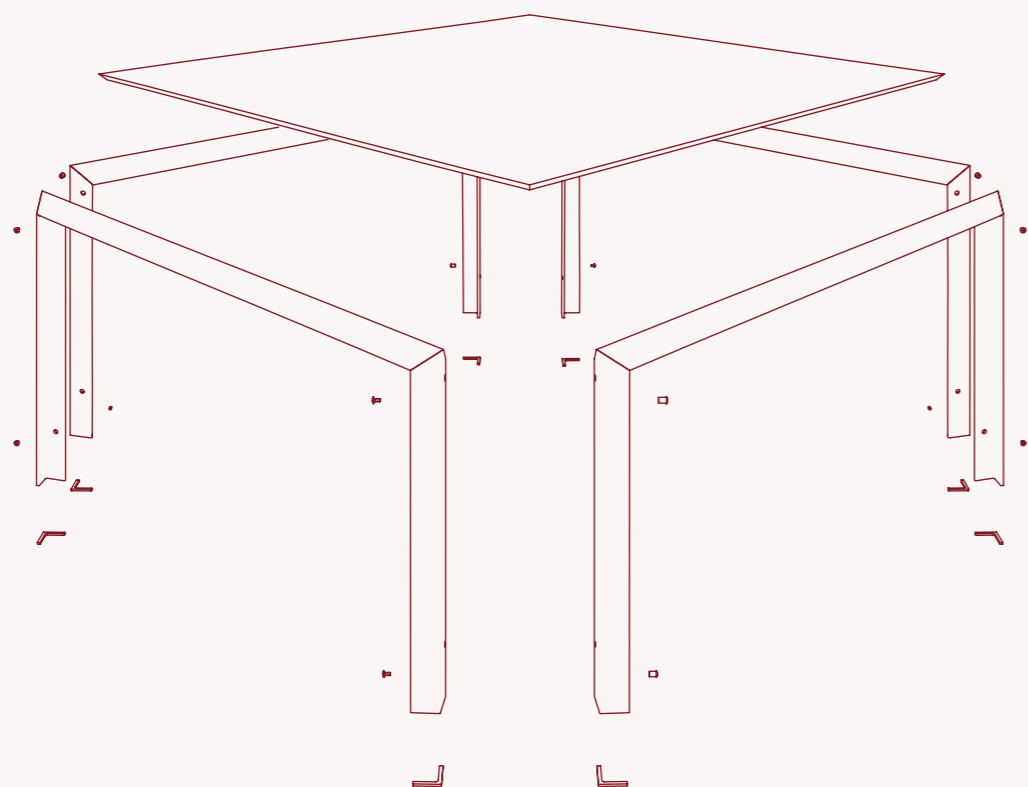

148

Dimensions Dimensioni

MM450.RE85

Rectangular table/
Tavolo rettangolare

Length/
Lunghezza: 145 cm
Depth/
Profondità: 85 cm
Height/
Altezza: 73 cm



MM450.QU145

Square table/
Tavolo quadrato

Length/
Lunghezza: 145 cm
Depth/
Profondità: 145 cm
Height/
Altezza: 73 cm

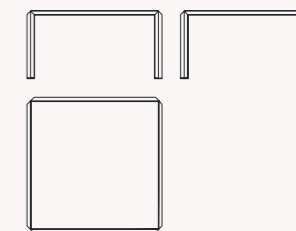

MM453.RE85

Rectangular table/
Tavolo rettangolare

Length/
Lunghezza: 185 cm
Depth/
Profondità: 85 cm
Height/
Altezza: 73 cm



MM451.RE95

Rectangular table/
Tavolo rettangolare

Length/
Lunghezza: 225 cm
Depth/
Profondità: 95 cm
Height/
Altezza: 73 cm

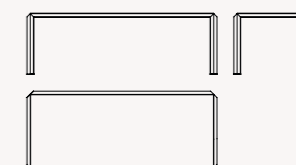

149

Technical description

Range of tables, coffee tables and consoles, with structure made of extruded aluminum profiles painted with epoxy powders in the specified colours.

Top with bevelled edges inserted flush into the structure, available in translucent or smoked acid-etched tempered glass (12 mm thick), Carrara, Marquinia, Tundra Grey marble or Taj Mahal quartzite (20 mm thick). Black polyethylene feet.

Descrizione tecnica

Sistema di tavoli, tavolini e consolle, con struttura realizzata con profili in alluminio estruso verniciata con polveri epossidiche nei colori indicati.

Piano con bordi smussati inserito a filo nella struttura, disponibile in cristallo temperato acidato traslucido o acidato fumé (spessore 12 mm), marmo di Carrara, marmo Marquinia, marmo Tundra Grey o quarzite Taj Mahal (spessore 20 mm). Piedini in polietilene nero.

Dimensions Dimensioni

MM452.RE95

Rectangular table/
Tavolo rettangolare

Length/
Lunghezza: 250 cm
Depth/
Profondità: 95 cm
Height/
Altezza: 73 cm

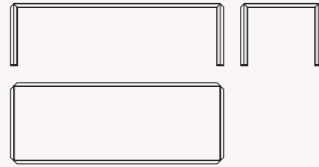

MM454.QU85

Square table/
Tavolino quadrato

Length/
Lunghezza: 85 cm
Depth/
Profondità: 85 cm
Height/
Altezza: 30 cm

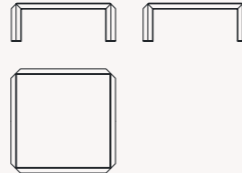

MM455.QU50

Square table/
Tavolino quadrato

Length/
Lunghezza: 50 cm
Depth/
Profondità: 50 cm
Height/
Altezza: 40 cm

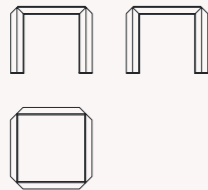

MM456

Rectangular console/
Consolle rettangolare

Length/
Lunghezza: 145 cm
Depth/
Profondità: 50 cm
Height/
Altezza: 80 cm

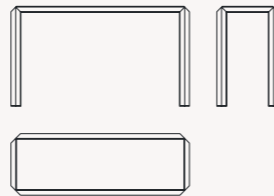

Finishes Finiture

Base
Base



AM - Ral 9006

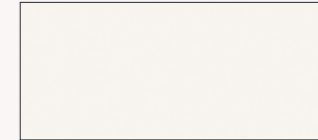

W - Ral 9010



GN - Ral 7021



N - Ral 9005

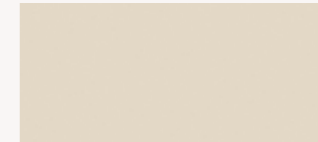

OW - Ral 1013



RR - Ral 3003



VO - Ral 6003

Top
Piano



CAT
Traslucent acid-etched crystal/
Cristallo acidato traslucido

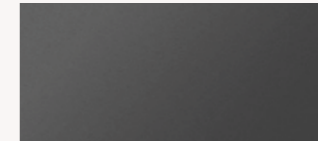

CG
Smoked acid-etched crystal/
Cristallo acidato fumé



MCA
Carrara marble/
Marmo Carrara

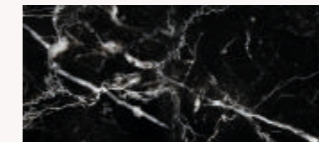

MMA
Marquinia marble/
Marmo Marquinia



MTG
Tundra Grey marble/
Marmo Tundra Grey



MTM
Taj Mahal quartzite/
Quarzite Taj Mahal

DESIGNER

152



Jeff Miller

Jeff Miller is a leading American industrial designer who for more than 30 years has received international acclaim for his innovative and distinctive style. In addition to running his eponymous New York consulting firm for numerous international clients, he headed the design of Poppin, developing clean, clever and colorful products and furniture for the office. Prior to that he was the long-time VP of Design for ECCO Design in New York. Jeff Miller earned his degree in Industrial Design from Carnegie Mellon University, where he graduated with University and Department Honors.

Jeff Miller è un importante industrial designer americano che da oltre 30 anni riceve consensi internazionali per il suo stile innovativo e distintivo. Oltre a gestire la sua omonima società di consulenza newyorkese per numerosi clienti internazionali, ha diretto il design di Poppin, sviluppando prodotti e mobili per ufficio puliti, intelligenti e colorati. In precedenza, è stato a lungo vicepresidente del design di ECCO Design a New York. Jeff Miller ha conseguito una laurea in Disegno Industriale presso la Carnegie Mellon University, dove si è laureato con il massimo dei voti.



Bentz, design Jeff Miller



Flipt, design Jeff Miller

153

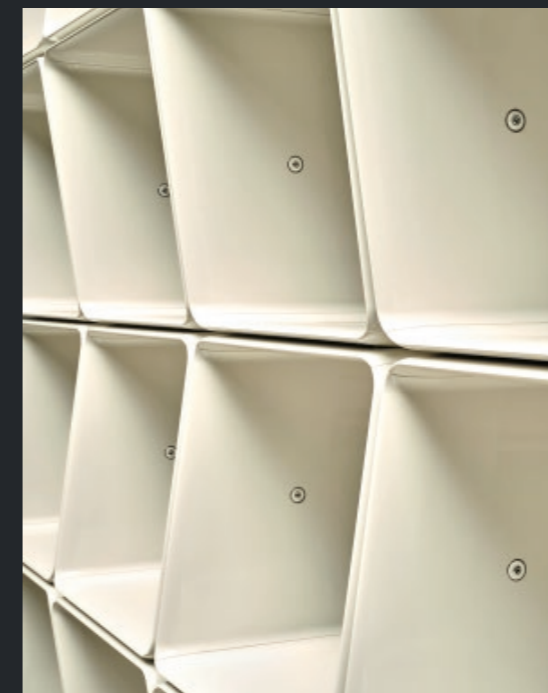

Obo, design Jeff Miller



Fratino, design Jeff Miller



Jeff Miller 2005



Bentz is a line of tables and low tables that can be completely disassembled and recycled. Available in square or round versions and in different heights, they have a cast aluminium base and transparent tempered glass tops.

The base of the Bentz table emerges from a profile that extends along a fluid line, forming a central focal point with the functional features of a column base. This configuration balances rationality and warmth, creating a visual harmony that combines a rigorous aesthetic with expressive details. Designed to encourage natural interaction, Bentz is completed by a reflective surface that echoes its surroundings, emphasizing its connection with the space. More than just a furnishing, Bentz is a shared experience, blending design and function to promote a new culture of daily living: essential, open, and sustainable.

Bentz è una linea di tavoli e tavolini completamente disassemblabili e riciclabili. Disponibili in versione quadrata o rotonda e in diverse altezze, hanno base in fusione di alluminio e piani in cristallo trasparente temperato.

La base del tavolo Bentz nasce da un profilo che si estende lungo una linea fluida, formando un fulcro centrale con le caratteristiche funzionali di una base a colonna. Una configurazione che bilancia razionalità e accoglienza, creando un'armonia visiva che unisce un'estetica rigorosa e dettagli espressivi. Pensato per favorire un'interazione naturale tra le persone, Bentz si completa con una superficie riflettente che richiama l'ambiente circostante, sottolineandone la connessione con lo spazio. Non solo complemento, ma esperienza di condivisione, Bentz unisce design e funzione sostenendo una nuova cultura del vivere quotidiano: essenziale, aperta, sostenibile.

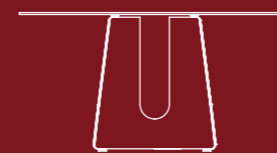
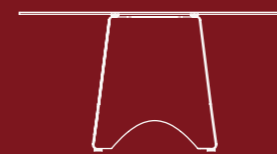
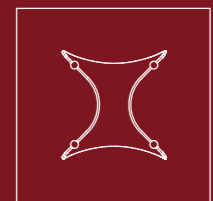
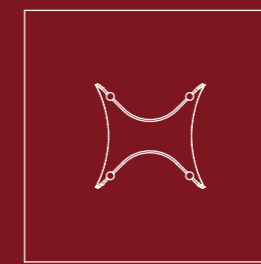
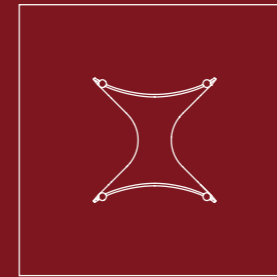

PRODUCT FACT SHEET SCHEDA PRODOTTO

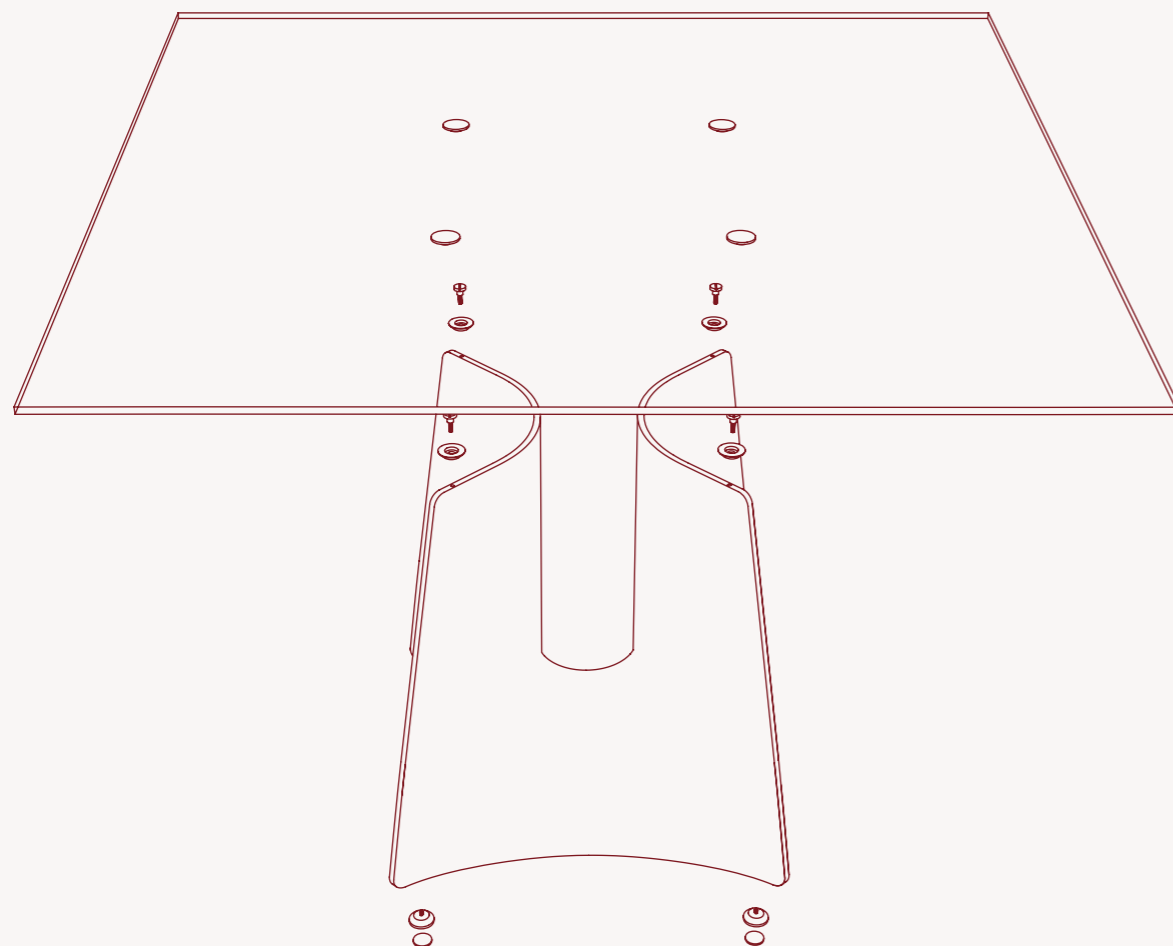

156

Dimensions Dimensioni

JM201.QU140

Square table/
Tavolo quadrato

Length/
Lunghezza: 140 cm
Depth/
Profondità: 140 cm
Height/
Altezza: 72 cm

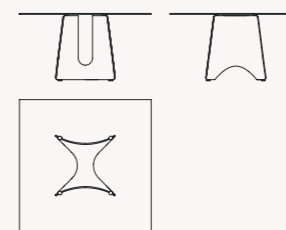

JM201.RO140

Round table/
Tavolo tondo

Diameter/
Diametro: 140 cm
Height/
Altezza: 72 cm

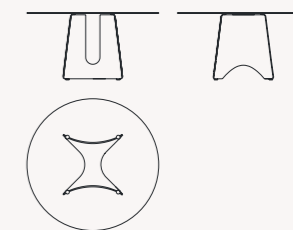

JM201.EL180

Elliptical table/
Tavolo ellittico

Length/
Lunghezza: 181 cm
Depth/
Profondità: 120 cm
Height/
Altezza: 72 cm

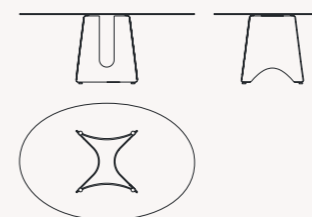

157

Technical description

Range of dining and low tables, with cast aluminum base in polished aluminum.

Transparent tempered glass top (10 mm thick).

Stainless steel feet.

Descrizione tecnica

Sistema di tavoli e tavolini, con base in fusione di alluminio lucidata.

Piano in cristallo trasparente temperato (spessore 10 mm).

Piedini in acciaio inox.

Dimensions Dimensioni

JM202.QU100

Square low table/
Tavolino quadrato

Length/
Lunghezza: 100 cm
Depth/
Profondità: 100 cm
Height/
Altezza: 37 cm

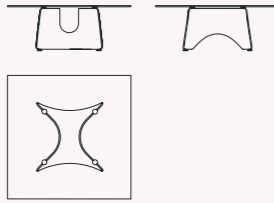

JM202.QU130

Square low table/
Tavolino quadrato

Length/
Lunghezza: 130 cm
Depth/
Profondità: 130 cm
Height/
Altezza: 37 cm

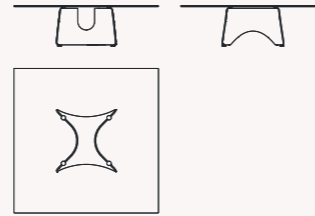

JM202.RO115

Round low table/
Tavolino tondo

Diameter/
Diametro: 115 cm
Height/
Altezza: 37 cm

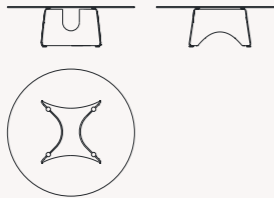

JM202.RO130

Round low table/
Tavolino tondo

Diameter/
Diametro: 130 cm
Height/
Altezza: 37 cm

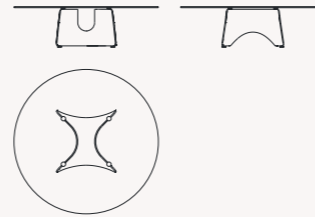

Finishes Finiture

Base
Base



LU
Polished aluminium/
Alluminio lucidato

Top
Piano



CT
Transparent crystal/
Cristallo trasparente

FLIPT



160

Jeff Miller 2005

Flipt is an armchair that can be converted into a chaise-longue. With steel frame and removable cover, it is available in various fabric or leather combinations, plain or two-tone.

The pleasure of relaxation, adapted to the essentials of urban life. Elegant and compact, Flipt discreetly conceals its true nature. When the occasion arises, it extends, doubling its length and transforming into a chaise-longue. A dual identity, versatile and welcoming, able to adapt without ever compromising functionality.

Flipt è una poltrona trasformabile in chaise-longue. Struttura in acciaio, rivestimento sfoderabile, disponibile in diverse combinazioni di tessuti o pelle, in tinta unita o bicolore.

Il piacere del relax, adattato all'essenzialità della vita urbana. Elegante e compatta, Flipt cela con discrezione la sua vera natura. Quando si presenta l'occasione si allunga, raddoppiando la propria estensione e trasformandosi in chaise-longue. Una doppia identità, versatile e accogliente, capace di modificarsi senza mai rinunciare alla funzionalità.

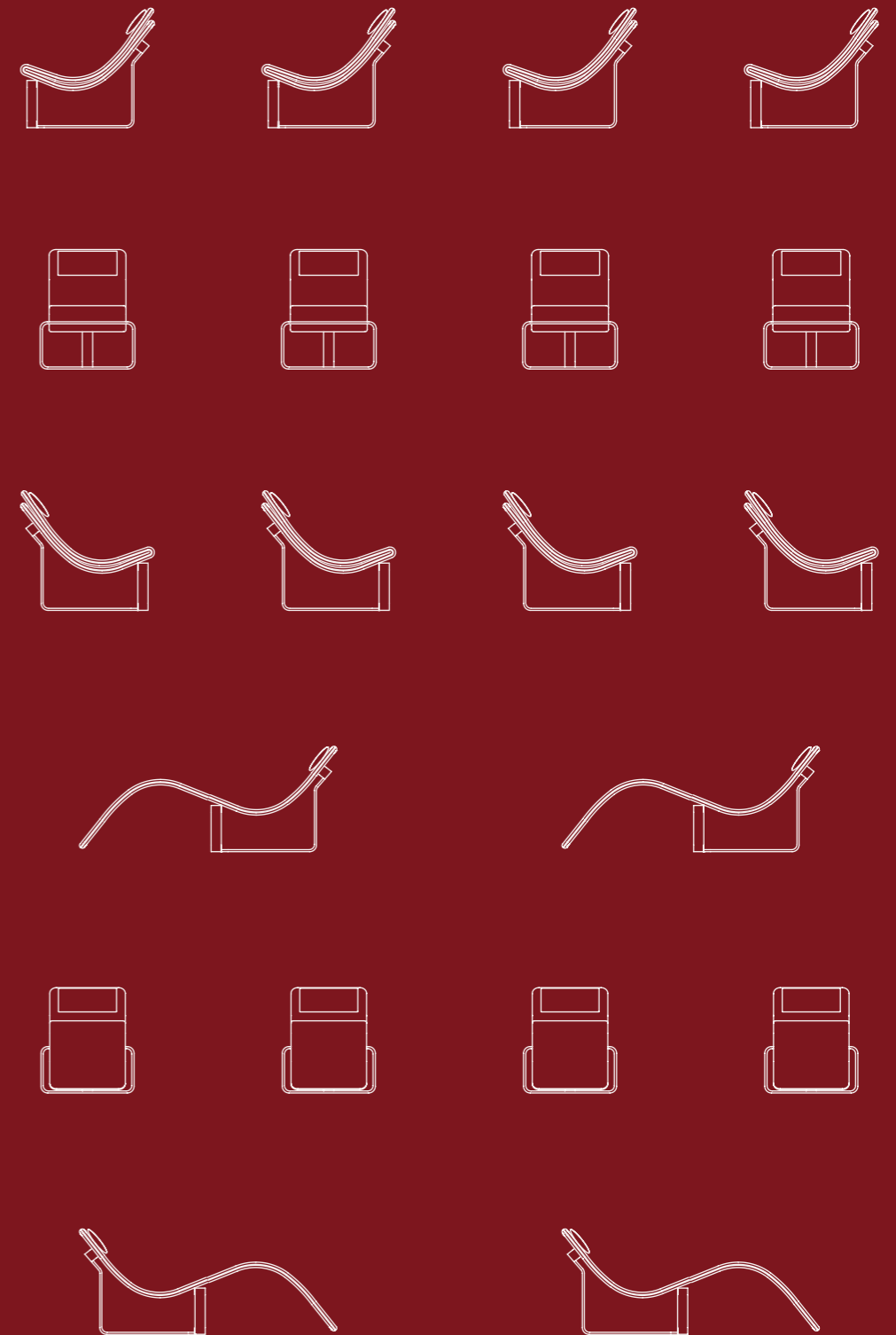

161

PRODUCT FACT SHEET SCHEDA PRODOTTO

162

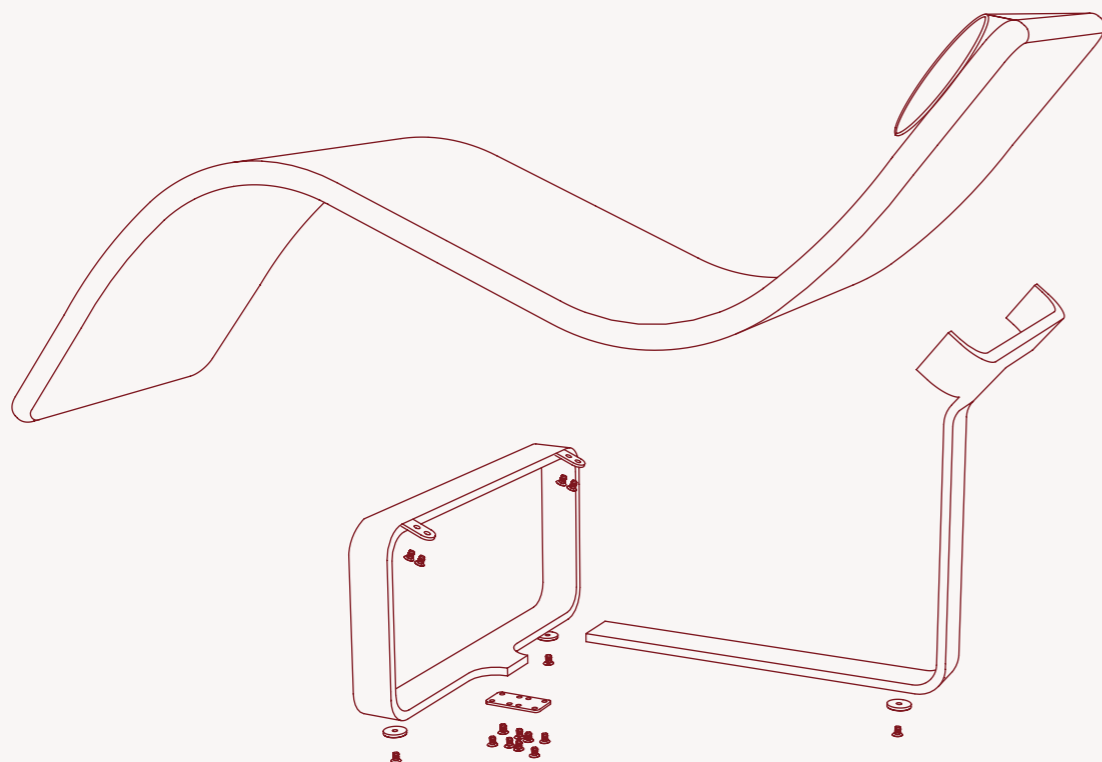

Technical description

Convertible armchair/chaise-longue with a steel structure painted in matt black or chrome.

Seat in flexible cold-foamed polyurethane and steel base.

A mechanism allows the seat to tip forward, opening and doubling in length.

Removable cover in fabric, technical fabric, leather, eco-leather, customer leather (pc) or customer fabric (tc).

Available in solid color or two colors, with the possibility of combining two different fabrics/leathers, with similar thickness.

Descrizione tecnica

Poltrona/chaise-longue trasformabile con struttura in acciaio verniciato in nero opaco o cromato.

Seduta in poliuretano flessibile schiumato a freddo e base in acciaio.

Un meccanismo permette alla seduta di ribaltarsi in avanti, aprendosi e raddoppiando in lunghezza.

Rivestimento sfoderabile in tessuto, tessuto tecnico, pelle, ecopelle, pelle cliente (pc) o tessuto cliente (tc).

Disponibile in tinta unita o in due colori, con la possibilità di abbinare due tessuti/pelli differenti, ma di simile spessore.

Dimensions Dimensioni

JM301

Armchair/
Poltrona

Length/
Lunghezza: 69 cm
Depth/
Profondità: 98 cm
Height/
Altezza: 87 cm

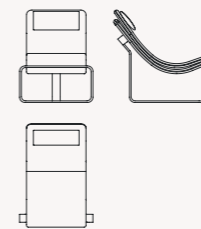

JM301

Chaise-longue/
Chaise-longue

Length/
Lunghezza: 69 cm
Depth/
Profondità: 189 cm
Height/
Altezza: 78 cm

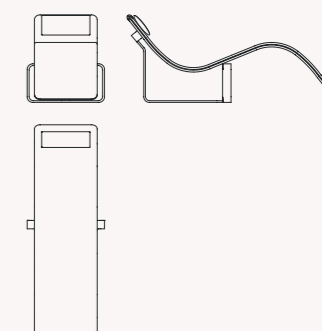

Finishes Finiture

Structure
Struttura



CR - Chromed/Cromato



N - Ral 9005

163

FRATINO



164

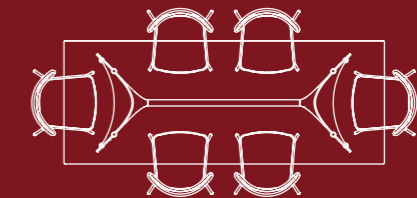
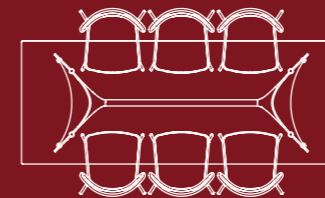
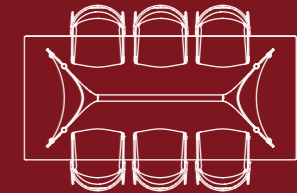
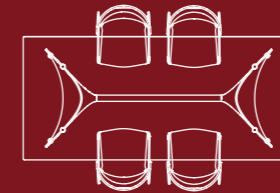

165

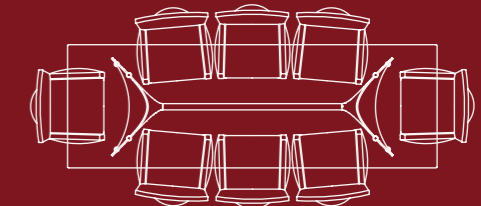
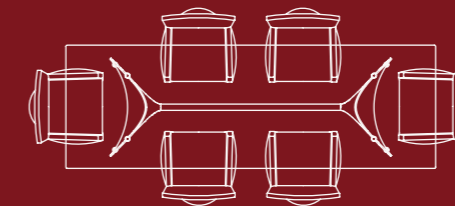

Jeff Miller 2009



Fratino is a line of tables that can be completely disassembled and recycled. The folding base is formed by two specular aluminium castings, joined by a crossbar. The rectangular top, in different sizes, is in tempered glass.

Fratino reinterprets the archetype of its traditional table counterpart, paying homage to the solidity and austere linearity that have defined its history. The structure, composed of two mirrored aluminium castings, is connected by an elliptical crossbeam, whose fluid form emerges in the glass tabletop, enhancing its robustness and warmth.

Fratino è una linea di tavoli completamente disassemblabile e riciclabile. La base ribaltabile è formata da due fusioni di alluminio speculari, unite da un traverso. Il piano rettangolare, in diverse dimensioni, è in cristallo temperato.

Fratino reinterpreta l'archetipo dell'omologa tipologia di tavolo, rendendo omaggio alla solidità e alla linearità austera che ne hanno segnato la storia. La struttura, composta da due fusioni speculari in alluminio, è collegata da un traverso ellittico, la cui forma fluida emerge nel piano in vetro, che ne enfatizza robustezza e accoglienza.

PRODUCT FACT SHEET SCHEDA PRODOTTO

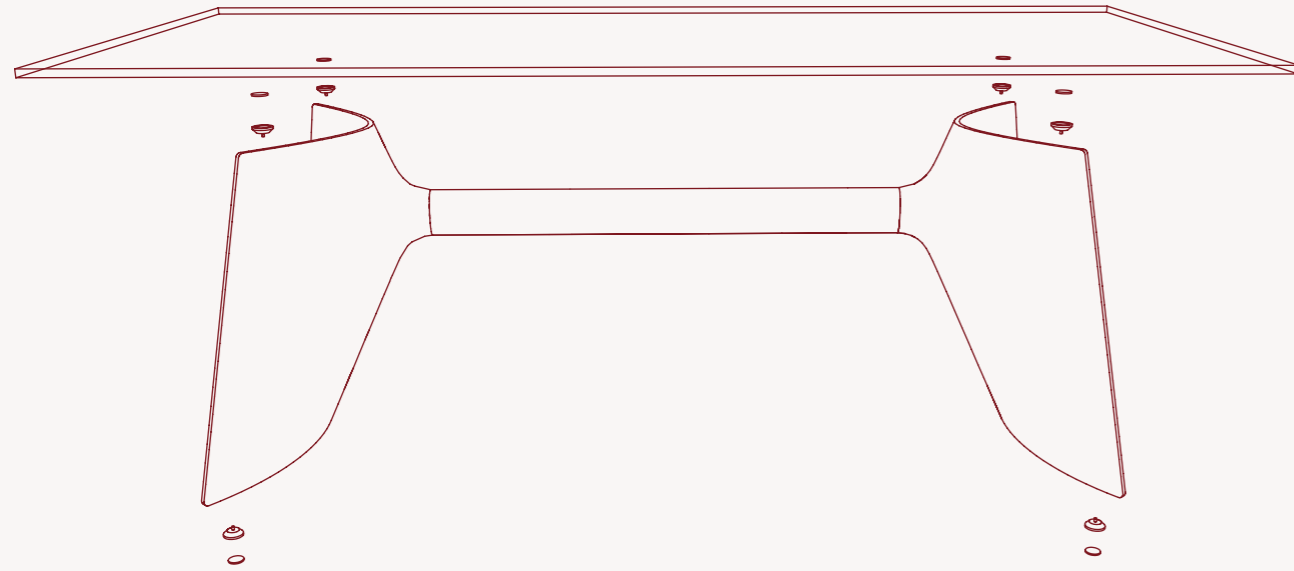

166

Technical description

Table with aluminum base consisting of two specular castings connected by an extruded crossbar with an elliptical cross-section.

Available in different sizes, with rectangular tops in transparent tempered glass (15 mm thick).

Base and crosspiece dimensions vary according to the size of the top.

The base can be flipped and used with the crosspiece up by reversing the position of the feet and top supports.

Stainless steel feet.

Descrizione tecnica

Tavolo con base in alluminio costituita da due fusioni speculari collegate da un traverso estruso a sezione ellittica.

Disponibile in diverse dimensioni, con piani rettangolari in cristallo trasparente temperato (spessore 15 mm).

Le dimensioni della base e del traverso variano secondo la misura del piano.

La base può essere ribaltata ed utilizzata con il traverso in alto invertendo la posizione dei piedini e dei supporti del piano.

Piedini in acciaio inox.

Dimensions Dimensioni

JM206.220

Rectangular table/
Tavolo rettangolare

Length/
Lunghezza: 220 cm
Depth/
Profondità: 100 cm
Height/
Altezza: 73 cm

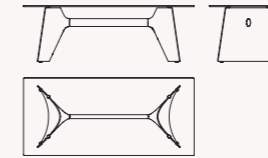

JM206.260

Rectangular table/
Tavolo rettangolare

Length/
Lunghezza: 260 cm
Depth/
Profondità: 100 cm
Height/
Altezza: 73 cm

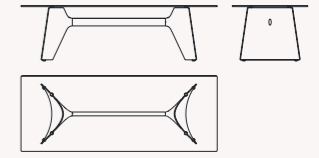

JM206.300

Rectangular table/
Tavolo rettangolare

Length/
Lunghezza: 300 cm
Depth/
Profondità: 100 cm
Height/
Altezza: 73 cm

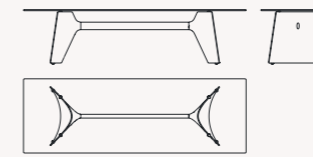

167

Finishes Finiture

Base
Base



LU
Polished aluminium/
Alluminio lucidato

Top
Piano



CT
Transparent crystal/
Cristallo trasparente



Jeff Miller
2007

Obo is a versatile and sustainable modular container made of 50% recycled and 100% recyclable plastic. The combination of modules allows different storage solutions. Available in black and white, it can also be used as a small table.

Side table, storage unit, bookshelf, wall: Obo is a modular system based on the repetition and combination of individual elements, offering innovative solutions for object storage and space division. Intelligent, versatile, and playful, the asymmetric design of each module allows for the creation of multifaceted and articulated compositions in three dimensions. Made from 50% recycled plastic and 100% recyclable, Obo is the perfect representation of the brand's commitment to sustainability.



Obo è un contenitore modulare versatile e sostenibile, realizzato in materiale plastico 50% riciclato e 100% riciclabile. La combinazione dei moduli permette di creare diverse soluzioni di contenimento. Disponibile nei colori bianco e nero, è utilizzabile anche come tavolino.

Tavolino, contenitore, libreria, parete: Obo è un sistema modulare che si basa sulla ripetizione e combinazione dei singoli elementi, offrendo soluzioni innovative per il contenimento degli oggetti e la separazione degli spazi. Intelligente, versatile e ludico, il design asimmetrico di ciascun modulo consente di creare composizioni multififormi e articolate su tre dimensioni. Realizzato in materiale plastico al 50% riciclato e 100% riciclabile, Obo è la perfetta rappresentazione dell'impegno del brand verso la sostenibilità.

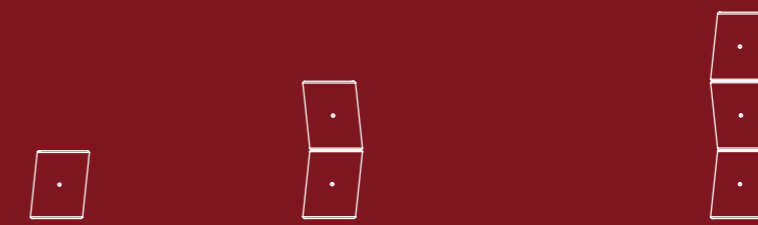
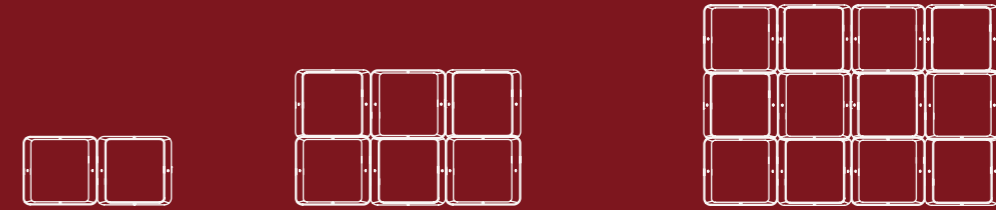
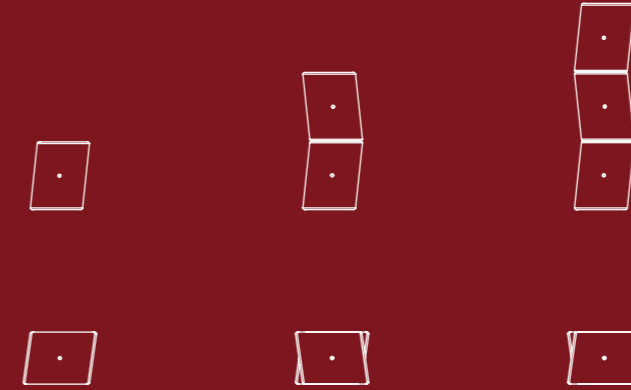
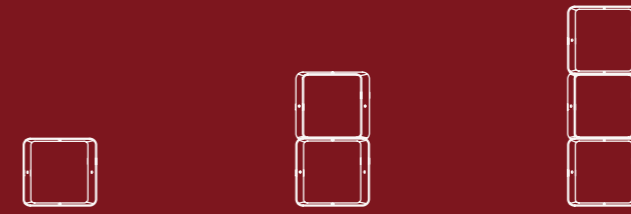

PRODUCT FACT SHEET SCHEMA PRODOTTO

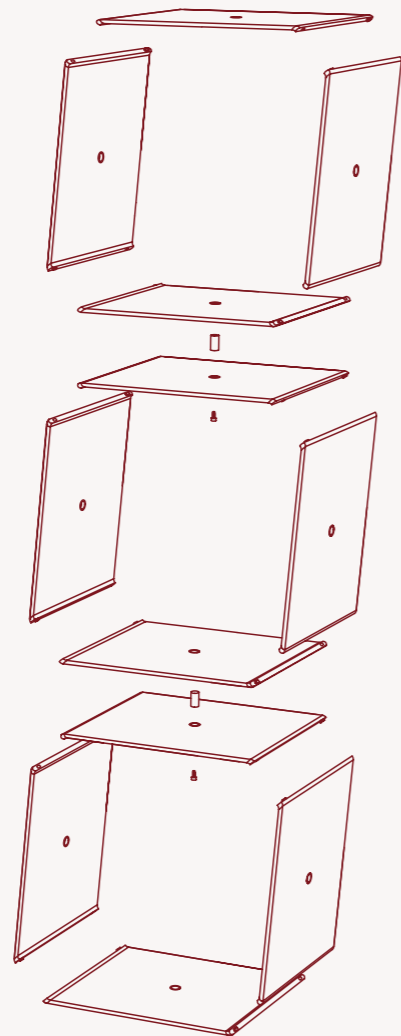

Dimensions Dimensioni

JM401

Modular container/
Contenitore modulare

Length/
Lunghezza: 38 cm
Depth/
Profondità: 34 cm
Height/
Altezza: 30 cm

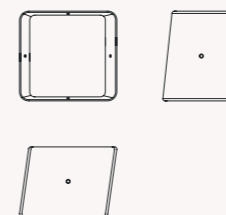

Finishes Finiture

Structure
Struttura

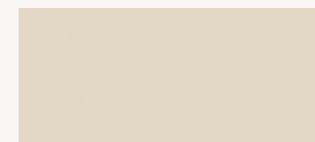

OW - Ral 1013



N - Ral 9005

170

171

Technical description

Modular container made of 50% recycled and 100% recyclable plastic material (SAN), on the repetition and combination of which is based a system for containing objects and separating spaces.

Each module comes with two white rubber connection joints - which can also be purchased separately - that allows it to be connected to other elements.

A wall or ceiling anchoring kit with a 200-cm steel cable is also available upon request, recommended to further stabilize compositions that exceed three elements in height.

Obo can also be used as a side table and it is available in the specified colours.

Descrizione tecnica

Contenitore modulare realizzato in materiale plastico (SAN) 50% riciclato e 100% riciclabile, sulla cui ripetizione e combinazione si basa un sistema di contenimento di oggetti e separazione di spazi.

Ogni modulo è fornito di due giunti di connessione in gomma bianca - acquistabili anche separatamente - che ne permettono il collegamento ad altri elementi.

E' inoltre disponibile a richiesta un kit di ancoraggio a parete o a soffitto con cavo di acciaio di 200 cm, consigliato per stabilizzare ulteriormente le composizioni che superino i tre elementi di altezza.

Obo può anche essere utilizzato come tavolino ed è disponibile nei colori indicati.

DESIGNER



172

Radice Orlandini

Andrea Radice and Folco Orlandini, in addition to their individual careers, have together signed several products with a highly personal and incisive style. Graduates at the Milan Politecnico, the first in industrial design, the second in architecture, meet after several work experiences. In 2008 they started a creative relationship that led to the implementation of several projects for Italian and international companies.

Andrea and Folco are guided by the idea that design should be conceived as an emotion that combines functionality with a form that lasts. They believe in designing projects that are the synthesis of three elements: paternity, irony and improvement. Each creation is followed through all stages of growth. From the first idea to the development to the production, every phase step by step. Irony, understood as a constant search for what goes beyond the simple and obvious meaning of the object, has always distinguished the way of life of the two designers and hence their design approach that is always based on an improvement of what already exists. Growing means improving and improving means to be able to design products that are always better, from a productive, aesthetic, ergonomic, economic, (and much more) point of view.

Andrea Radice e Folco Orlandini oltre alle proprie carriere individuali hanno firmato insieme diversi prodotti dallo stile fortemente personale e incisivo. Laureati al politecnico di Milano, il primo in disegno industriale, il secondo in architettura, si incontrano dopo varie esperienze lavorative. Nel 2008 cominciano un rapporto creativo che li porta alla realizzazione di numerosi progetti per aziende Italiane ed internazionali.

Andrea e Folco, guidati dall'idea di design inteso come emozione che unisce alla funzionalità l'estetica che dura nel tempo, credono nell'ideazione di progetti che siano la sintesi di tre elementi: paternità, ironia e miglioramento. Ogni loro creazione viene seguita attraverso tutte le fasi di crescita. Dall'idea iniziale alla maturazione fino alla realizzazione, ogni momento è accompagnato mano a mano. L'ironia, intesa come costante ricerca di ciò che va oltre il semplice ed evidente significato dell'oggetto, contraddistingue da sempre il modo di vivere dei due designer e quindi il loro approccio progettuale che tutte le volte è improntato a un miglioramento di ciò che già esiste. Crescere significa migliorare e migliorare vuol dire riuscire a ideare prodotti che siano sempre superiori ai precedenti a livello funzionale, estetico, produttivo, ergonomico, economico e molto altro ancora.



Kin, design Radice Orlandini

173

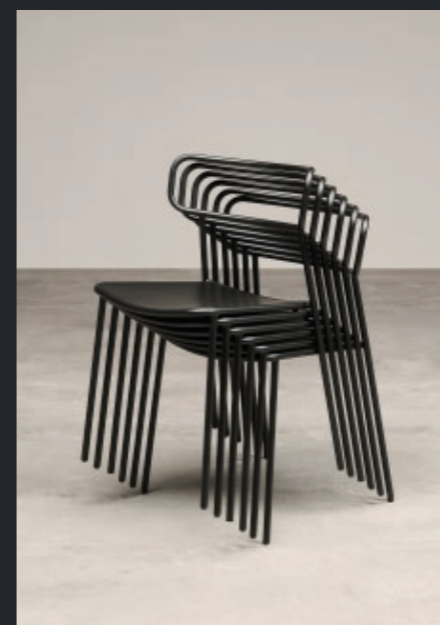

Paloma, design Radice Orlandini



Radice Orlandini 2018

Kin is an upholstered seating and stool system with a reduced armrest. The frame is made of steel, the upholstery is available in different materials and colours.

Like in Japanese Kintsugi, where every crack becomes valuable, this chair designed by Radice and Orlandini merges distinct parts into a new aesthetic, suggesting a deliberately unstable balance. The supporting structure, invisible, allows a visual contrast between the components, which, with different materials and finishes, accentuate the discontinuity, transforming it into harmony. The armrests, minimal yet functional, provide support without being bulky, allowing the chair to be comfortably placed under the table. An object rich in values and meaning, an authentic expression of design that combines pragmatism and utopia.

Kin è un sistema di sedute e sgabelli imbottiti con bracciolo ridotto. La struttura è in acciaio, il rivestimento è disponibile in diversi materiali e colori.

Come nel Kintsugi giapponese, dove ogni frattura diventa valore, questa sedia progettata da Radice e Orlandini fonde parti distinte in un'estetica nuova, suggerendo un equilibrio volutamente instabile. La struttura portante, invisibile, lascia emergere un contrasto visivo tra le componenti, che con materiali e finiture diverse ne accentuano la discontinuità, trasformandola in armonia. I braccioli, minimali ma funzionali, offrono appoggio senza essere voluminosi, permettendo di posizionare comodamente la sedia sotto il tavolo. Un oggetto denso di valori e significati, espressione autentica di un design che unisce pragmatismo e utopia.

PRODUCT FACT SHEET SCHEDA PRODOTTO

176

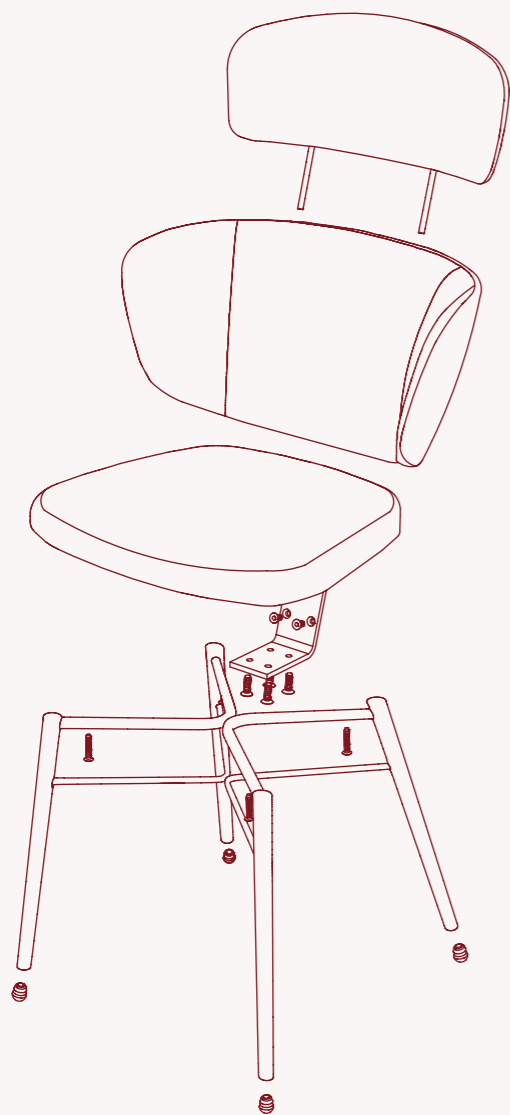

Technical description

Range of seats and stools with reduced armrests.

Steel tube structure painted in the specified colours.

Cold-foamed flexible polyurethane backrest.

Non-removable cover in fabric, technical fabric, leather, eco-leather, customer leather (pc) or customer fabric (tc).

Black polyethylene feet.

Descrizione tecnica

Sistema di sedute e sgabelli imbottiti con bracciolo ridotto.

Struttura in tubo di acciaio verniciato in polvere epossidica nei colori indicati.

Schienale in poliuretano flessibile schiumato a freddo.

Rivestimento non sfoderabile in tessuto, tessuto tecnico, pelle, eco-pelle, pelle cliente (pc) o tessuto cliente (tc).

Piedini in polietilene nero.

Dimensions Dimensioni

OD101

Upholstered chair/
Sedia rivestita

Length/
Lunghezza: 54 cm
Depth/
Profondità: 57 cm
Height/
Altezza: 84 cm



OD103

Upholstered bar stool/
Sgabello bar rivestito

Length/
Lunghezza: 54 cm
Depth/
Profondità: 56 cm
Height/
Altezza: 93 cm



OD102

Upholstered kitchen stool/
Sgabello da cucina rivestito

Length/
Lunghezza: 54 cm
Depth/
Profondità: 56 cm
Height/
Altezza: 83 cm



177

Finishes Finiture

Structure
Struttura



CR - Chromed/Cromato



AM - Ral 9006



N - Ral 9005

PALOMA

178

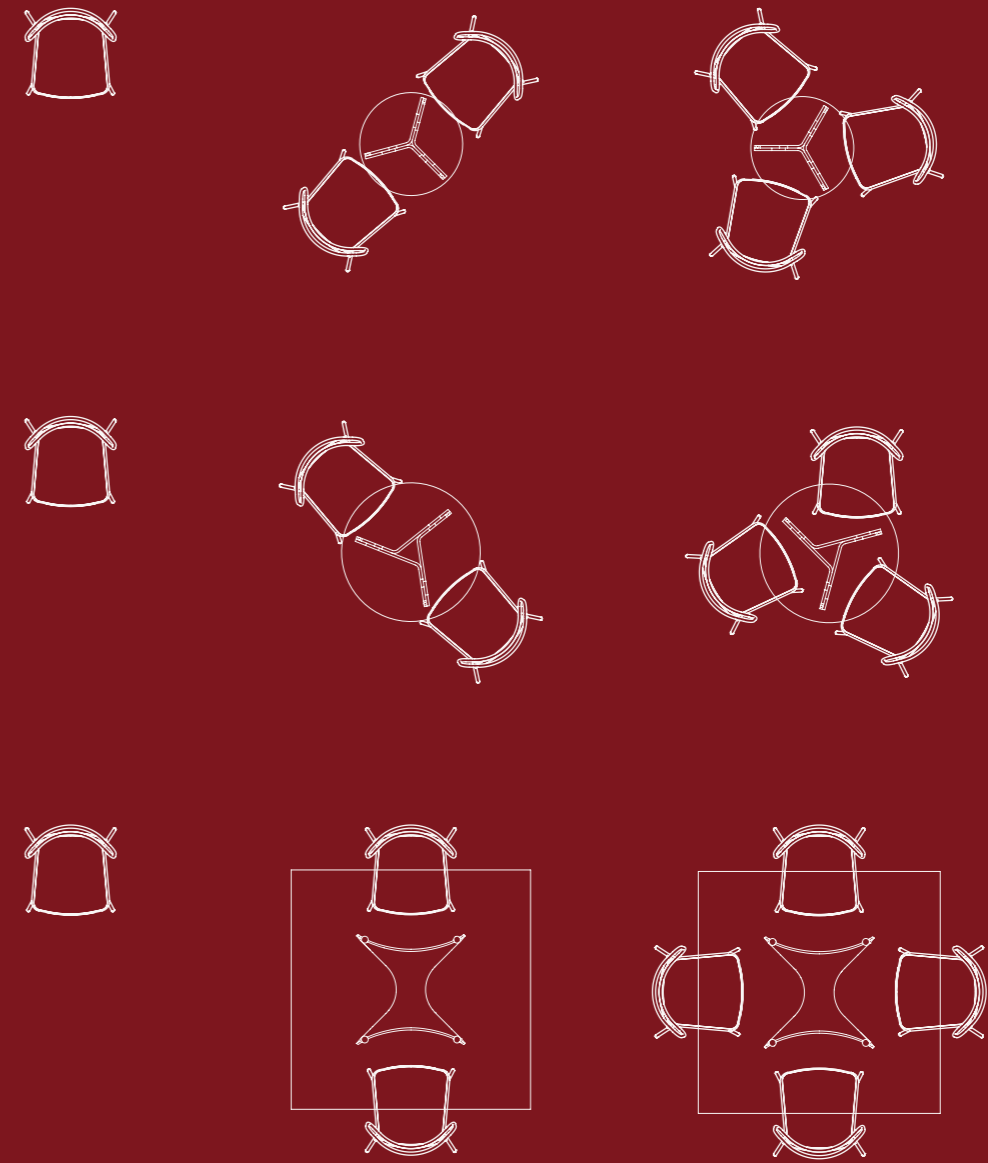

179

Radice Orlandini 2019



Paloma is a stackable chair, completely disassemblable and recyclable, that can be used both indoors and outdoors. The seat and frame are made of stainless steel, available in seven colours.

Paloma transforms the spontaneous gesture of a pencil into a three-dimensional object, a graphic mark that captures on paper the idea of a chair through a minimalist approach, free from embellishments and complications. A bent tube in space clearly outlines the contours of the chair, highlighting its distinctive shape. A design with an immediate emotional impact, elevating Paloma to the archetype of the chair itself.

Paloma è una sedia impilabile, completamente disassemblabile e riciclabile, adatta ad un utilizzo sia all'interno che all'esterno. Il sedile e la struttura sono realizzati in acciaio inox, disponibile in sette colori.

Paloma trasforma in un oggetto tridimensionale il gesto spontaneo della matita, segno grafico che fissa su carta l'idea di una sedia secondo un approccio minimale, libero da sovrascritture e privo di complicazioni. Un tubo piegato nello spazio delinea con chiarezza i contorni della sedia, mettendo in risalto la sua forma distintiva. Un design dall'impatto emotivo immediato, che eleva Paloma ad archetipo della sedia stessa.

PRODUCT FACT SHEET SCHEDA PRODOTTO

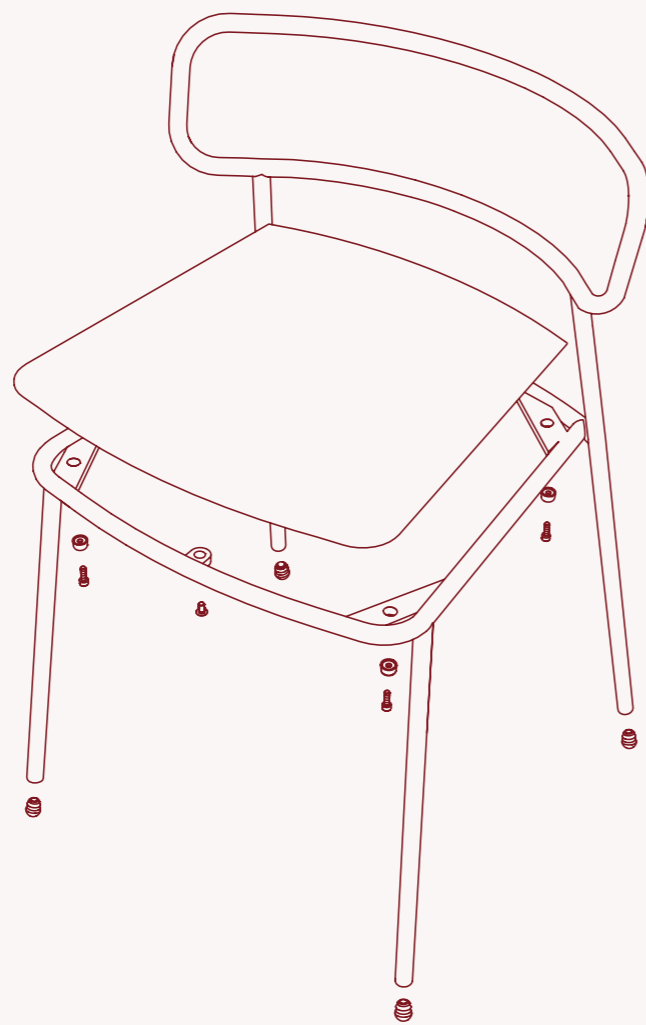

180

Dimensions Dimensioni

OD104

Stackable chair/
Sedia impilabile

Length/
Lunghezza: 53 cm
Depth/
Profondità: 52 cm
Height/
Altezza: 79 cm



Finishes Finiture

Structure
Struttura



AM - Ral 9006

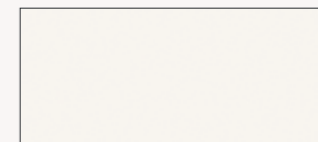

W - Ral 9010

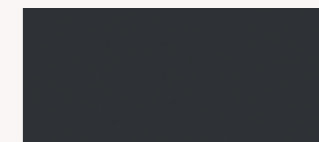

GN - Ral 7021



N - Ral 9005

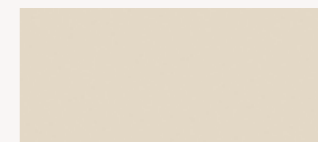

OW - Ral 1013



RR - Ral 3003



VO - Ral 6003

181

Technical description

Stackable chair with AISI 304 stainless steel sheet seat.

AISI 304 stainless steel tubular frame.

Painted with epoxy powders in the specified colours.

Descrizione tecnica

Sedia impilabile con sedile in lamiera inox AISI 304.

Struttura in tubolare di acciaio inox AISI 304.

Verniciatura con polveri epossidiche nei colori indicati.



Denis Santachiara

His training is self-taught, starting as a Car Stylist in the Italian motor valley at MWM in Modena and then at Maserati.

Since 1977 he has proposed works between art and design, exhibited at the Venice Biennale 1980, "All the arts tend towards Performance" Palazzo dei Diamanti, Ferrara 1982, Documenta 8 Kassel 1988, Milan Triennale 1982/84/86/96/01/04, Rome Quadrennial 1998, Pac Milan 1999, Valencia Biennale 2005, St Etienne Biennale 2006, "Domani ora" - Luxembourg Art Museum 2007.

In 1984 he proposed "La Neomerce, the design of invention and artificial ecstasy", Milan Triennale and Centre Pompidou in Paris, an exhibition manifesto and international reference for a new performative, technopoetic design; introducing a new and unprecedented relationship with technology into design.

La sua formazione è autodidatta, iniziata come Stylist Car nella motor valley italiana presso la MWM di Modena e poi in Maserati.

Dal 1977 propone opere tra arte e design ed espone alla Biennale di Venezia 1980, "Tutte le arti tendono alla Performance" Palazzo dei Diamanti, Ferrara 1982, Documenta 8 Kassel 1988, Triennale di Milano 1982/84/86/96/01/04, Quadriennale di Roma 1998, Pac di Milano 1999, Biennale di Valencia 2005, Biennale di St Etienne 2006, "Domani ora" - Museo d'arte del Lussemburgo 2007.

Nel 1984 propone "La Neomerce, il design dell'invenzione e dell'estasi artificiale", Triennale di Milano e Centre Pompidou di Parigi, mostra manifesto e riferimento internazionale per un nuovo design performativo, tecnopoetico; introducendo nel design un nuovo e inedito rapporto con la tecnologia.



Tato, design Denis Santachiara



Mama, design Denis Santachiara



Denis Santachiara 1995

Mama is a rocking armchair with a height-adjustable headrest. The removable cover is available in fabric, leather or eco-leather, or can be customised.

"A relaxing and continuous lullaby in the welcoming embrace of a Mama, always ready to cuddle; this is the spirit of the armchair that comes alive cuddling and cradling in the domestic space, involving the whole body from head to toe."

This is how designer Denis Santachiara defines and describes his Mama: the very essence of relaxation and home comfort.

Mama è una poltrona a dondolo con poggiatesta regolabile in altezza. Il rivestimento sfoderabile è disponibile in tessuto, pelle o eco-pelle, oppure personalizzabile.

"Una rilassante e continua ninna nanna di una Mama accogliente, sempre pronta a coccolarti. Ecco lo spirito di questa poltrona che si anima cullando, coinvolgendo tutto il corpo, dalla testa ai piedi".

Così il designer Denis Santachiara definisce e racconta la sua Mama: essenza stessa del relax e del comfort domestico.

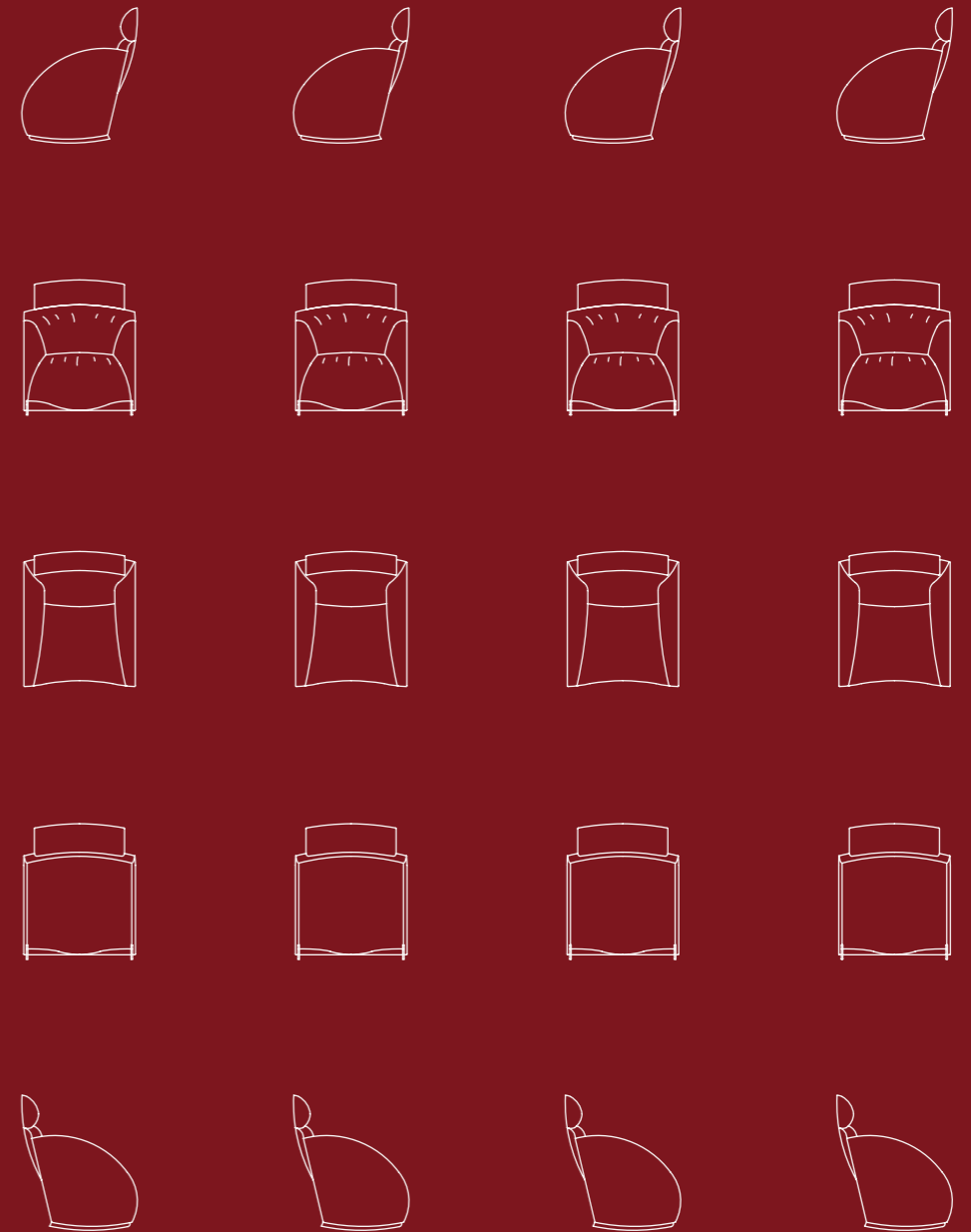

PRODUCT FACT SHEET SCHEDA PRODOTTO

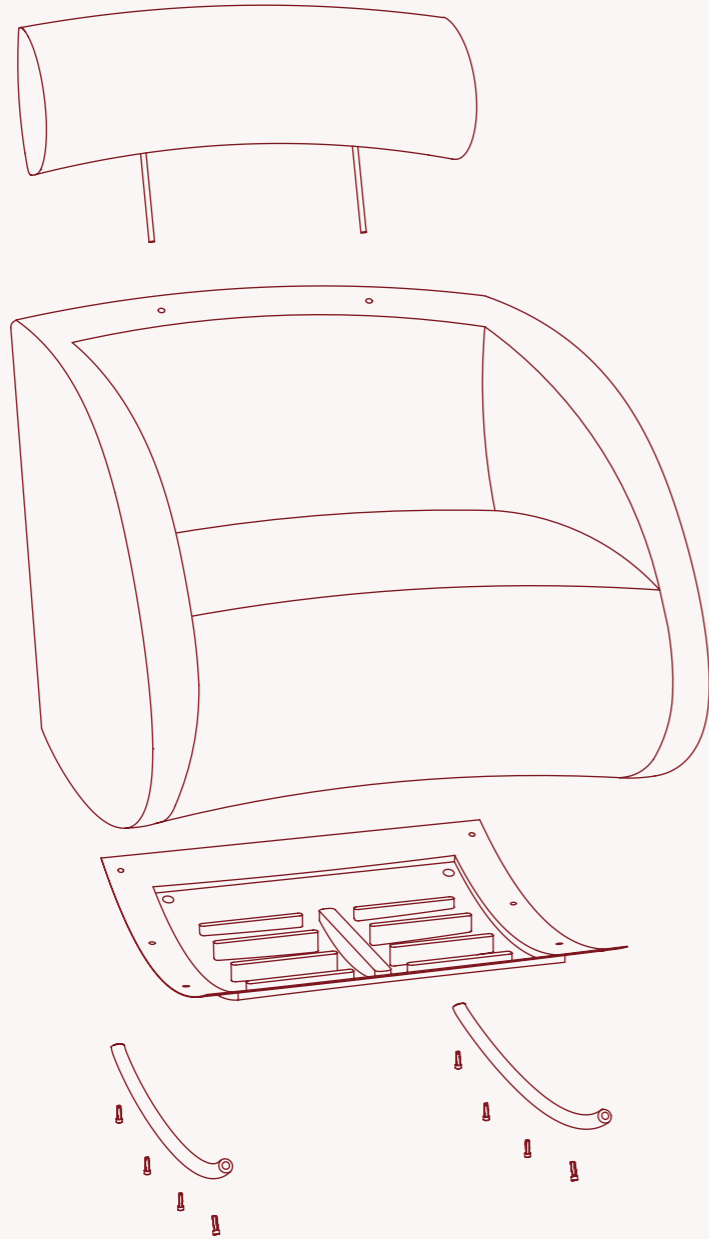

186

Dimensions Dimensioni

DS852

Rocking armchair/
Poltrona a dondolo

Length/
Lunghezza: 77 cm
Depth/
Profondità: 80 cm
Height/
Altezza: 76 cm

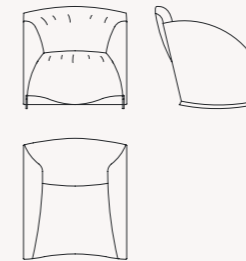

DS854

Headrest/
Poggiatesta

Length/
Lunghezza: 70 cm
Depth/
Profondità: 18 cm
Height/
Altezza: 46 cm

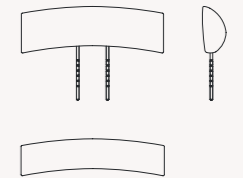

187

Technical description

Rocking armchair with adjustable headrest.

Internal steel structure.

Cold-foamed flexible polyurethane padding.

Available with removable cover in fabric, technical fabric, leather, eco-leather, customer leather (pc) or customer fabric (tc).

Black plastic and rubber skids, feet and bottom.

Descrizione tecnica

Poltrona a dondolo con poggiatesta regolabile in altezza.

Struttura interna in acciaio.

Imbottitura in poliuretano flessibile, schiumato a freddo.

Disponibile con rivestimento sfoderabile in tessuto, tessuto tecnico, pelle, ecopelle, pelle cliente (pc) o tessuto cliente (tc).

Pattini, piedini e fondo in materiale plastico e gomma neri.

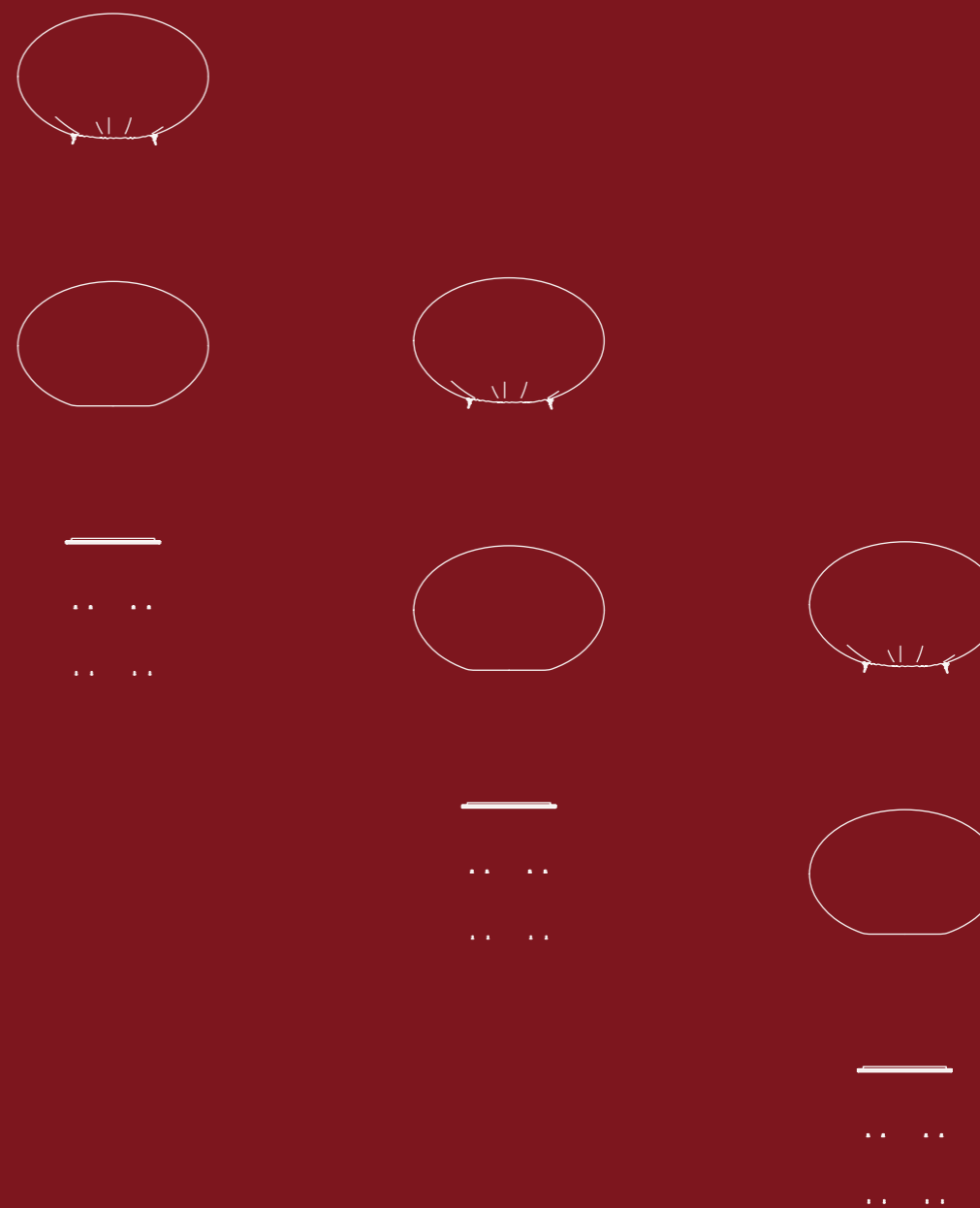

Denis Santachiara
1995

Tato is a family of poufs or footrests with a rigid base and different shapes, made of flexible material. The removable cover, easy to replace, is made of bi-elastic fabric, available in many colours.

Tato is pure, essential form. A sphere that captures the eye with its ideal balance and surprises with its comfortable elasticity. The technology of eco-friendly foams and a rigid plastic structure allow Tato to perfectly adapt to the body, returning to its original geometry. Beneath its minimalist appearance lies an unexpected density, making Tato a free, bold object to observe, move, and reinvent. The only limit? Your imagination.

Tato è una famiglia di pouf o poggiapiedi con base rigida e diverse forme, realizzati in materiale flessibile. Il rivestimento sfoderabile, facile da sostituire, è in tessuto bi-elastico, disponibile in tantissimi colori.

Tato è forma pura, essenziale. Una sfera che cattura lo sguardo con il suo equilibrio ideale e sorprende con la sua comoda elasticità. La tecnologia di schiume ecologiche e la struttura in plastica rigida permettono a Tato di adattarsi perfettamente al corpo, per poi ritornare alla sua geometria originale. Sotto l'apparenza minimalista si cela una densità inattesa, che rende Tato un oggetto libero, audace, da osservare, spostare, reinventare. L'unico limite? La propria immaginazione.

PRODUCT FACT SHEET SCHEDA PRODOTTO

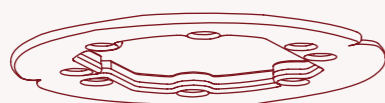
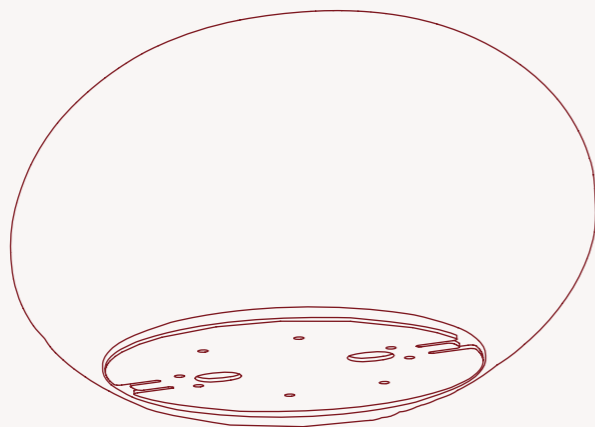

Dimensions Dimensioni

DS855

Seating and footrest/
Seduta e poggiapiedi



Length/
Lunghezza: 65 cm
Depth/
Profondità: 44 cm
Height/
Altezza: 42 cm



190

191

Technical description

Elastic seat/ovoid footrest, made of flexible, cold-foamed, polyurethane.

Rigid internal structure of polystyrene foam.

Elastomer bottom.

Two side cuts collect the removable bi-elastic fabric cover, available in two types of fabric and various colors.

Descrizione tecnica

Seduta elastica/poggiapiedi ovoidale, realizzato in poliuretano flessibile, schiumato a freddo.

Struttura interna rigida in polistirene espanso.

Fondo in elastomero.

Due tagli laterali raccolgono il rivestimento sfoderabile in tessuto bi-elastico, disponibile in due tipologie di tessuto e vari colori.

DESIGNER

192



Philippe Starck

Philippe Starck, world famous creator with multifaceted inventiveness, is always focused on the essential, his vision: that creation, whatever form it takes, must improve the lives of as many people as possible.

By employing his prolific work across all domains, from everyday products (furniture, a citrus-squeezer, electric bikes, an individual wind turbine), to architecture (hotels, restaurants that aspire to be stimulating places) and naval and spatial engineering (mega yachts, space habitation module), he continually pushes the boundaries and requirements of design, becoming one of the most visionary and renowned creators of the international contemporary scene.

In 1984 and 1985, Philippe Starck collaborated with Baleri Italia to create five pieces of furniture: Café Chair, Francesca Spanish, Richard III, Président M and Mac Gee. Visionary and timeless, these now-iconic creations are still a successful production today.

Philippe Starck, designer di fama mondiale dall'inventiva poliedrica, è sempre concentrato sull'essenziale, sulla sua visione: la creazione, in ogni sua forma, deve migliorare la vita del maggior numero possibile di persone.

Grazie a un prolifico lavoro in tutti i settori, dai prodotti di uso quotidiano (mobili, uno spremi agrumi, biciclette elettriche, una turbina eolica individuale), all'architettura (hotel, ristoranti che aspirano a essere luoghi stimolanti) fino all'ingegneria navale e spaziale (mega yacht, modulo abitativo spaziale), Starck continua incessantemente a sfidare i confini e le esigenze del design, diventando uno dei designer più visionari e rinomati della scena contemporanea internazionale.

Nel 1984 e nel 1985, Philippe Starck collabora con Baleri Italia per creare cinque prodotti: Café Chair, Francesca Spanish, Richard III, Président M e Mac Gee. Visionarie e senza tempo, queste creazioni ormai iconiche continuano a essere un successo ancora oggi.



Café Chair, design Philippe Starck



Mac Gee, design Philippe Starck



Président M, design Philippe Starck

193

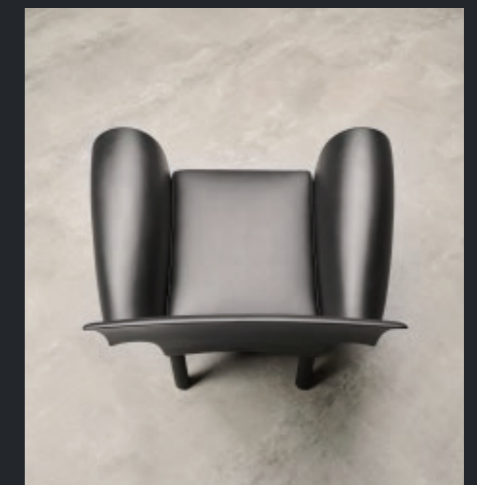

Richard III, design Philippe Starck

CAFÉ CHAIR



194

Philippe Starck 1984

Café Chair is a line of chairs and stools with a painted steel frame and a seat made of rubber latex and black polypropylene straps.

Café Chair is the chair designed by Philippe Starck, France's most renowned designer, for what was once the most famous café in France: Café Costes in Paris. A perfect blend of solidity and comfort, it features light lines that integrate harmoniously in both public and private settings. Café Chair is an object crafted to stand the test of time, where apparent simplicity is paired with a wealth of meaningful details.



Café Chair è una linea di sedie e sgabelli con struttura in acciaio verniciato e seduta composta da cinghie in lattice di gomma e polipropilene nero.

Café Chair è la sedia disegnata da Philippe Starck, il più famoso designer francese, per quello che ai tempi era il più celebre caffè francese: Café Costes a Parigi. Perfetta unione di solidità e comfort, è caratterizzata da linee leggere capaci di integrarsi armoniosamente in contesti sia pubblici che privati. Café Chair è un oggetto pensato per resistere alla prova del tempo, in cui l'apparente semplicità è abbinata a una densità di dettagli significativi.

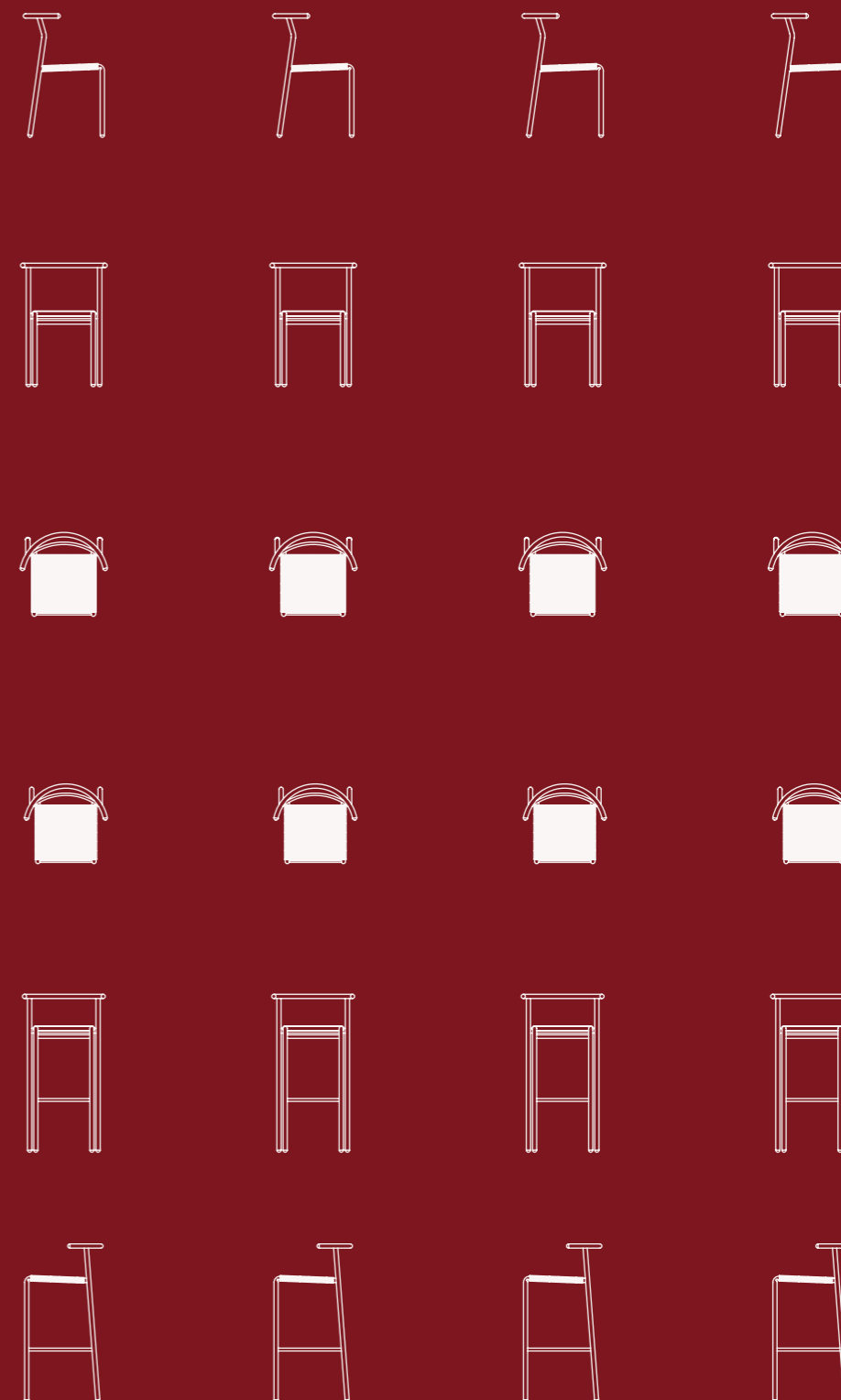

195

PRODUCT FACT SHEET SCHEDA PRODOTTO

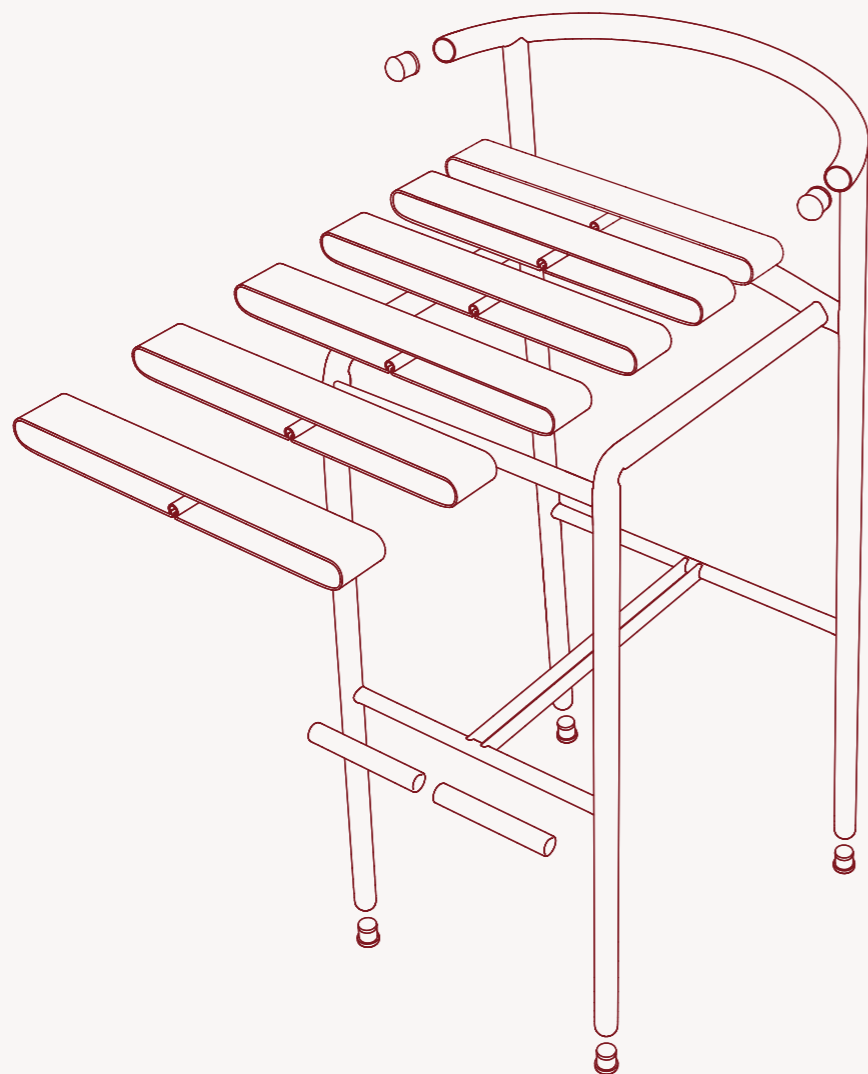

Dimensions Dimensioni

PS210

Stackable chair/
Sedia impilabile

Length/
Lunghezza: 53 cm
Depth/
Profondità: 50 cm
Height/
Altezza: 75 cm

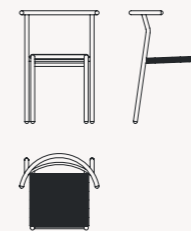

PS212

Kitchen stool/
Sgabello da cucina

Length/
Lunghezza: 53 cm
Depth/
Profondità: 50 cm
Height/
Altezza: 84 cm

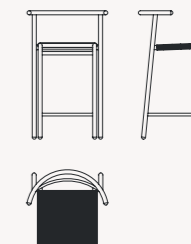

PS213

Bar stool/
Sgabello bar

Length/
Lunghezza: 53 cm
Depth/
Profondità: 50 cm
Height/
Altezza: 100 cm

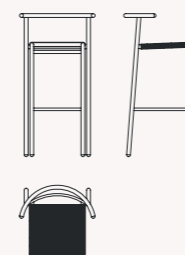

Finishes Finiture

Structure
Struttura



AM - Ral 9006



N - Ral 9005

196

197

Technical description

Range of seats and stools with structure in steel tubing painted with epoxy powders in the specified colours.

Seat made of lasten (rubber latex straps and black polypropylene).

Black rubber caps and feet.

Descrizione tecnica

Sistema di sedute e sgabelli con struttura in tubo di acciaio verniciato con polveri epossidiche nei colori indicati.

Sedile realizzato in lasten (cinghie in lattice di gomma e polipropilene nero).

Tappi e piedini in gomma nera.

MAC GEE

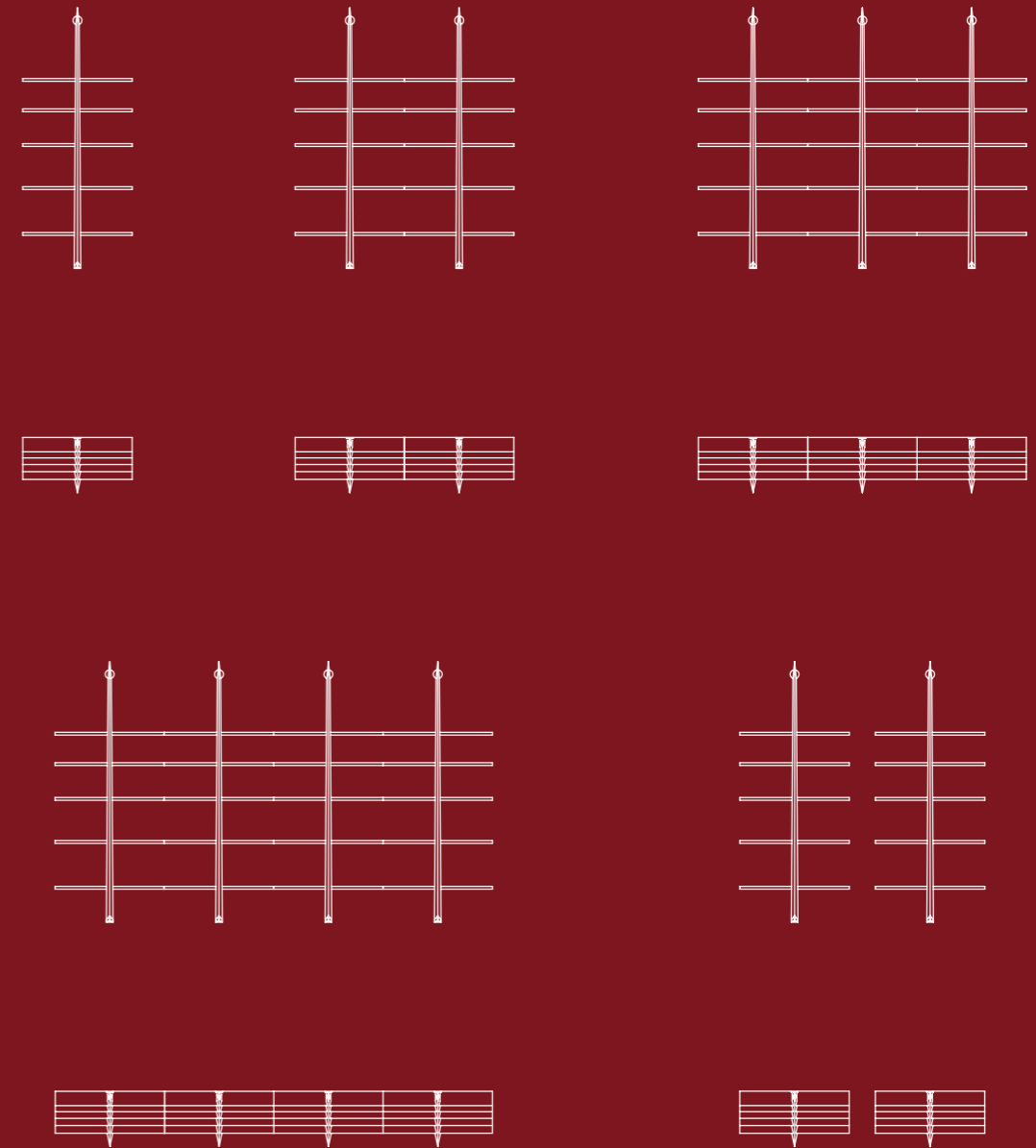

198

199

Philippe Starck 1984



Mac Gee is a painted steel bookcase that can be completely disassembled and recycled. It has five shelves with decreasing depth and is available in matt black, matt white or metallic silver.

Mac Gee is the very essence of a bookshelf. Philippe Starck has refined its structure to retain only the core, the skeleton of an authentic and coherent object. Avoiding any specific style or classification, the Mac Gee bookshelf stands on its own, simply leaning against the wall, almost like an objet trouvé, capable of adapting to any interior and transcending trends.

Mac Gee è una libreria in acciaio verniciato, completamente disassemblabile e riciclabile. Dispone di cinque ripiani a profondità decrescente ed è disponibile nei colori nero opaco, bianco opaco o argento metallizzato.

Mac Gee è l'essenza stessa di una libreria. Philippe Starck ne ha affinato la struttura fino a mantenere solo il nucleo, lo scheletro di un oggetto autentico e coerente. Evitando qualsiasi stile e classificazione, la libreria Mac Gee vive in autonomia, semplicemente appoggiata al muro, quasi come un objet trouvé, capace di adattarsi a ogni interno e di superare le tendenze.

PRODUCT FACT SHEET SCHEDA PRODOTTO

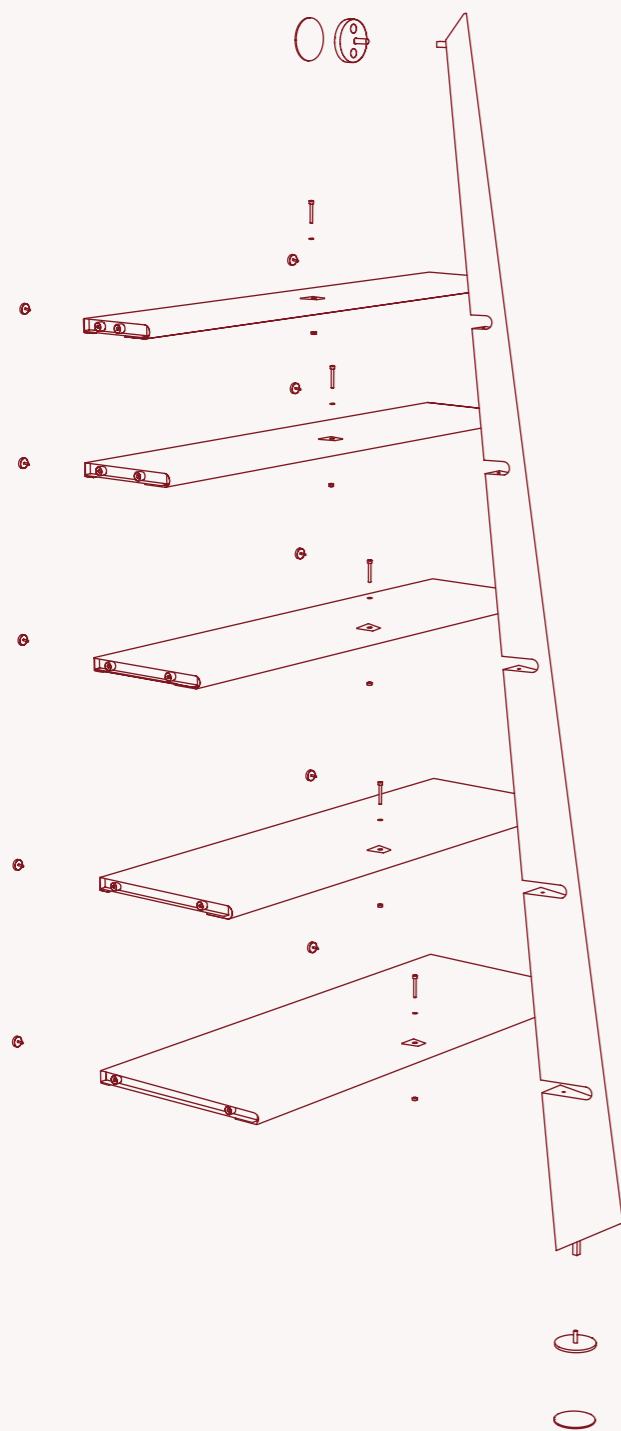

Dimensions Dimensioni

PS209

Bookshelf/
Libreria

Length/
Lunghezza: 99 cm
Depth/
Profondità: 50 cm
Height/
Altezza: 236 cm

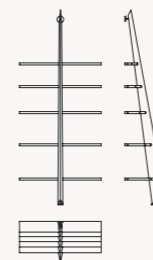

Finishes Finiture

Structure
Struttura

AM - Ral 9006

W - Ral 9010

N - Ral 9005

201

Technical description

Modular sheet steel bookcase consisting of a central upright and five shelves with decreasing depth.

Painted with epoxy powders in the specified colours.

Black rubber wall spacers.

Descrizione tecnica

Libreria componibile in lamiera d'acciaio, costituita da un montante centrale e cinque ripiani a profondità decrescente.

Verniciata con polveri epossidiche nei colori indicati.

Distanziali a muro in gomma nera.

PRESIDENT M

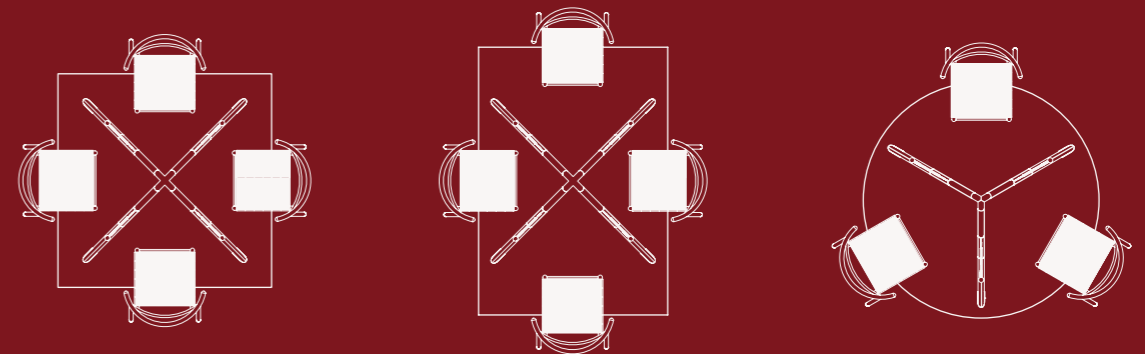
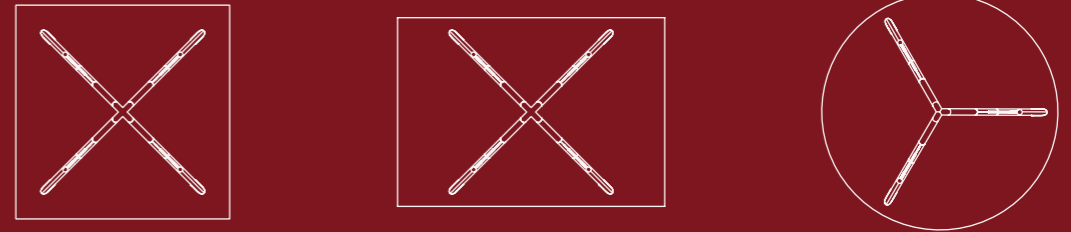

202

203

Philippe Starck 1984



President M is a line of tables with a disassemblable and recyclable structure. The structure has three or four legs, depending on the model, and is available in metallic silver or matt black. The glass top is offered in various sizes.

President M is the table designed for François Mitterrand's private study at the Élysée Palace. A project that expresses the contrast between lightness and density, both in materials and meaning. Composed of only three structural parts, it is fully disassemblable. The legs form a secondary structure that supports the true load-bearing elements of the transparent crystal top: die-cast, ribbed shapes that evoke shark fins, angel wings, and biomorphic silhouettes. Visually incongruous forms that are perfectly functional, upon which the top seems to levitate.

President M è una linea di tavoli con struttura disassemblabile e riciclabile. Struttura a tre o quattro gambe, a seconda del modello, disponibile con finitura argento metallizzato o nero opaco. Il piano in cristallo è disponibile in diverse dimensioni.

President M è il tavolo disegnato per lo studio privato di François Mitterrand all'Eliseo. Un progetto che esprime la contrapposizione tra leggerezza e densità, nei materiali e nel significato. Composto da sole tre parti strutturali, è totalmente disassemblabile. Le gambe costituiscono una struttura secondaria che sorregge i veri elementi portanti del piano in cristallo trasparente: sagome pressofuse nervate che evocano pinne di pescecane, ali d'angelo e silhouette biomorfe. Forme visivamente incongrue e perfettamente funzionali su cui il piano sembra levitare.

PRODUCT FACT SHEET SCHEDA PRODOTTO

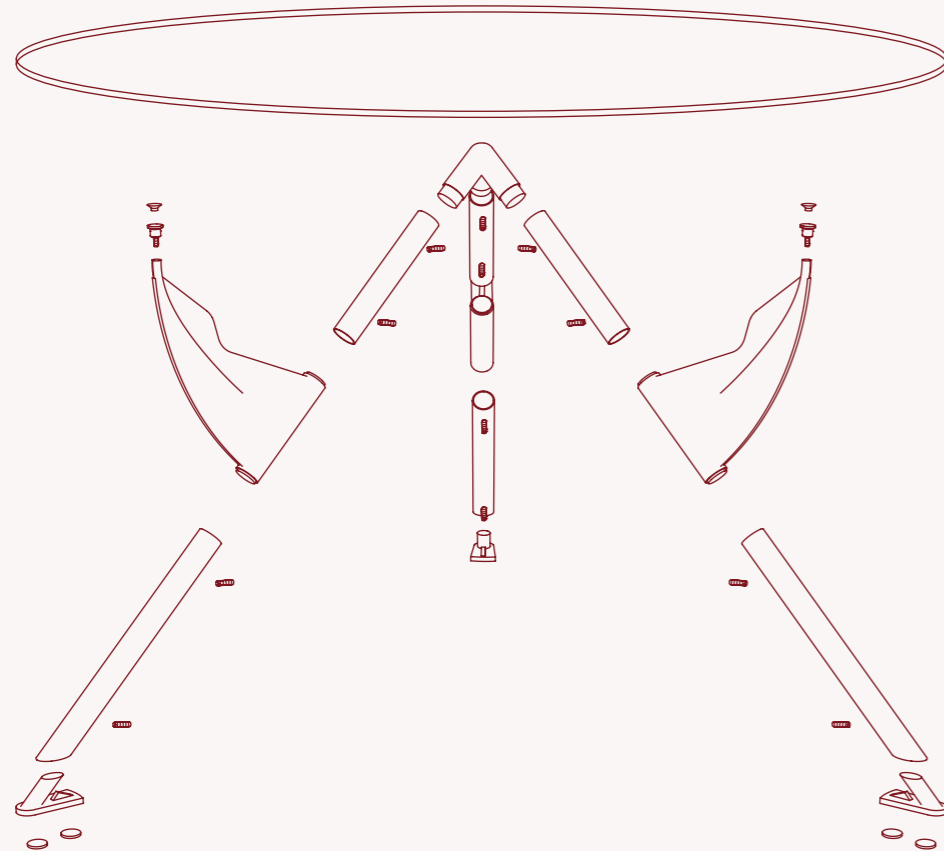

204

205

Dimensions Dimensioni

PS203.Q

Square table/
Tavolo quadrato

Length/
Lunghezza: 136 cm
Depth/
Profondità: 136 cm
Height/
Altezza: 74 cm

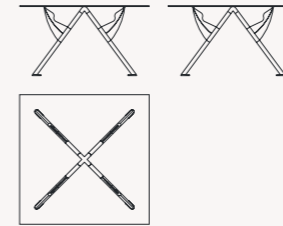

PS203.R

Rectangular table/
Tavolo rettangolare

Length/
Lunghezza: 170 cm
Depth/
Profondità: 120 cm
Height/
Altezza: 74 cm

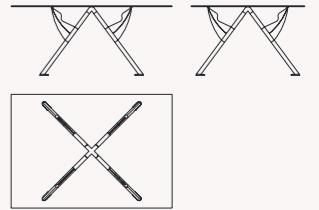

PS204

Round table/
Tavolo tondo

Diameter/
Diametro: 150 cm
Height/
Altezza: 73 cm

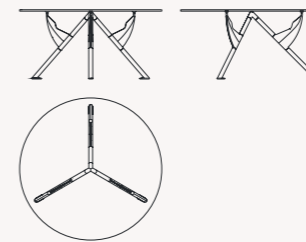

Finishes Finiture

Base
Base

AM - Ral 9006

N - Ral 9005

Top
Piano

Transparent crystal/
Cristallo trasparente

CT
Transparent crystal/
Cristallo trasparente

Technical description

Table with disassemblable three or four leg structure made of steel tube and aluminum castings painted with epoxy powders in the specified colours.

Tempered clear glass top (15 mm).

Descrizione tecnica

Tavolo con struttura disassemblabile a tre o quattro gambe in tubo di acciaio e fusioni di alluminio verniciato con polveri epossidiche nei colori indicati.

Piano in cristallo trasparente temperato (10 mm).

RICHARD III



206

Philippe Starck 1985

Richard III is an armchair with a fully molded frame painted in matt black. The removable cover is available in fabric, leather or eco-leather in different colours, or can be customised.

An highly symbolic armchair, recalling and reinterpreting the essence of bourgeois décor. Richard III is inspired by the sight of old club chairs abandoned on the street, to which Philippe Starck decided to give new life, modernizing them and transforming them into evergreen objects. Created with the interiors of the President's private apartment in the Élysée Palace in mind, the Richard III became François Mitterrand's favorite armchair.

Richard III è una poltrona con struttura interamente stampata e verniciata in nero opaco. Il rivestimento sfoderabile è disponibile in tessuto, pelle o eco-pelle in diversi colori, oppure personalizzabile.

Una poltrona altamente simbolica, che richiama e reinterpreta l'essenza del decoro borghese. La Richard III è ispirata dalla vista di vecchie poltrone da club abbandonate per strada, alle quali Philippe Starck decise di donare nuova vita, attualizzandole e trasformandole in oggetti evergreen. Creata immaginando gli interni dell'appartamento privato del Presidente nel Palazzo dell'Eliseo, la Richard III divenne la poltrona preferita di François Mitterrand.



207

PRODUCT FACT SHEET SCHEDA PRODOTTO

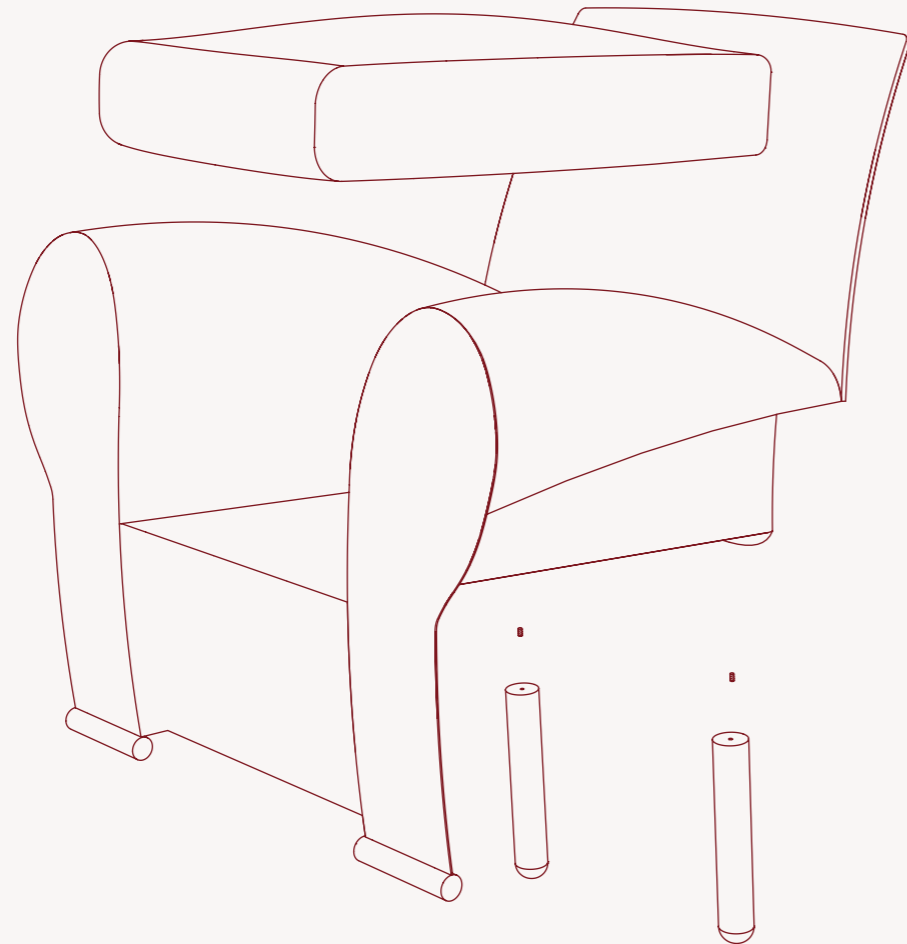

208

Dimensions Dimensioni

PS215

Armchair/
Poltrona

Length/
Lunghezza: 94 cm
Depth/
Profondità: 90 cm
Height/
Altezza: 100 cm

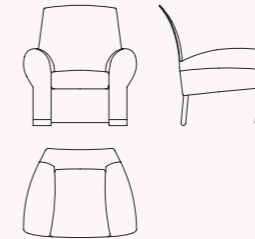

Finishes Finiture

Structure
Struttura



N - Ral 9005

209

Technical description

Armchair with fully molded structure made of structural rigid polyurethane.

Painted with polyurethane enamels in RAL 9005 matt Jet Black.

Cushion in expanded polyurethane foam and dacron.

Removable cover in fabric, technical fabric, leather, eco-leather, customer fabric (tc) or customer leather (pc).

Descrizione tecnica

Poltrona con struttura interamente stampata in poliuretano rigido strutturale.

Verniciatura con smalti poliuretanic in Nero Intenso opaco RAL 9005.

Cuscino in poliuretano espanso e dacron.

Rivestimento sfoderabile in tessuto, tessuto tecnico, pelle, eco-pelle, tessuto cliente o pelle cliente.

DESIGNER

210



Hannes Wettstein

Born in 1958 in Ascona, Switzerland, he lived and worked in Zurich. His main professional activities were in the fields of product design and interior architecture.

He designed fashion and furniture showrooms, public spaces, hotels, installations, offices, both in Switzerland and abroad. He designed limited edition collections of furnishings and accessories for several Swiss companies. His projects include furniture, lamps, watches, eyeglasses, rugs, handles, bikes.

His collaboration with Baleri Italia began in 1985; he designed several many successful products for the company. Hannes Wettstein died in July 2008, only 50 years old.

Nasce nel 1958 ad Ascona, in Svizzera, vive e lavora a Zurigo. Il suo lavoro è orientato principalmente verso il product design e l'architettura d'interni.

Realizza showroom di moda e di arredamento, spazi collettivi, alberghi, allestimenti, uffici, in Svizzera e all'estero. Progetta e realizza mobili e accessori in collezioni limitate per alcune industrie svizzere. Disegna mobili, lampade, orologi, occhiali, tappeti, maniglie, biciclette.

Inizia la sua collaborazione con Baleri Italia nel 1985 e firma molti pezzi di successo per l'azienda. Hannes Wettstein scompare a soli 50 anni nel luglio 2008.



Capri Collection, design Hannes Wettstein

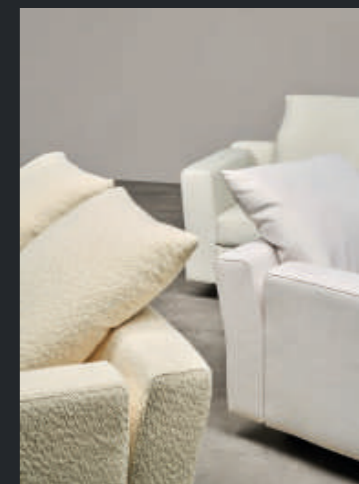

Bill, design Hannes Wettstein



Juliette, design Hannes Wettstein

211

BILL



212

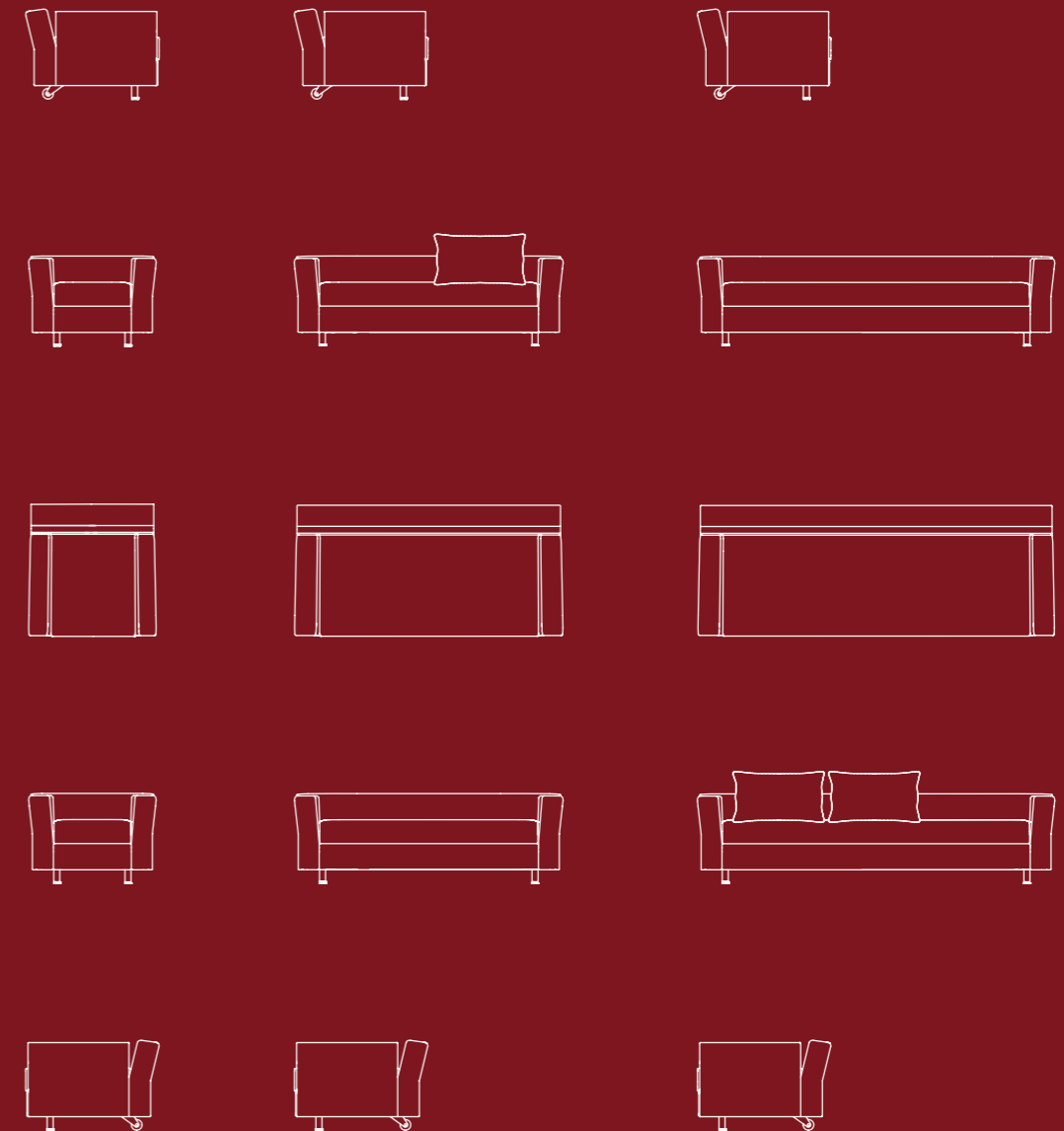

213

Hannes Wettstein 1994

Bill is a line of versatile sofas, suitable for domestic and public spaces, with removable covers available in different materials.

Designed by Hannes Wettstein to complement the Capri series, the Bill sofa features a design free of radical risks and unnecessary ornamentation. Measured, composed, and with a restrained, versatile functionality, Bill offers great freedom of use. Easily adaptable to both domestic and public spaces, Bill embodies the pleasure of a natural, effortless discretion that finds its elegance in simplicity.

Bill è una linea di divani versatili, adatti a spazi domestici e pubblici, con rivestimento sfoderabile disponibile in diversi materiali.

Progettato da Hannes Wettstein per integrare la serie Capri, il divano Bill ha un design privo di azzardi radicali e ornamenti superflui. Misurato, composto e dalla funzionalità sobria e versatile, Bill suggerisce una grande libertà d'uso. Capace di adattarsi con disinvoltura a spazi domestici e pubblici, Bill restituisce il piacere di una discrezione naturale, senza sforzo apparente, che trova la propria eleganza nella semplicità.

PRODUCT FACT SHEET SCHEDA PRODOTTO

214

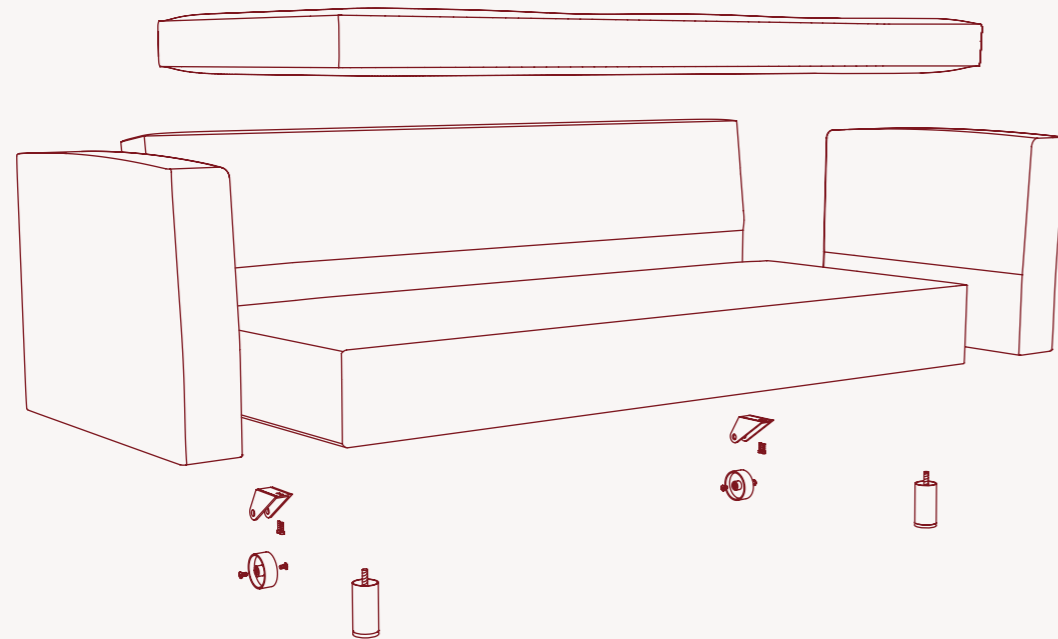

Technical description

Range of sofas and armchairs with internal structure made of multilayer wood.

Padding and optional folding cushion, adaptable to the backrest structure, in elastic polyurethane foam.

Front steel feet powder-coated in the specified colours, rear metal casters.

Removable cover composed of various housse (seat, back and armrests) in fabric, technical fabric, leather, eco-leather, customer leather (pc) or customer fabric (tc).

Descrizione tecnica

Sistema di divani e poltrone, con struttura interna in legno multistrato.

Imbottitura e cuscino pieghevole opzionale, che si adatta alla struttura dello schienale, in poliuretano espanso elastico.

Piedini anteriori in acciaio verniciato a polvere nei colori indicati, ruote posteriori in metallo.

Rivestimento sfoderabile composto da varie housse (seduta, schienale e braccioli) in tessuto, tessuto tecnico, pelle, eco-pelle, pelle cliente (pc) o tessuto cliente (tc).

Dimensions Dimensioni

HW645

Armchair/
Poltrona

Length/
Lunghezza: 85 cm
Depth/
Profondità: 89 cm
Height/
Altezza: 60 cm

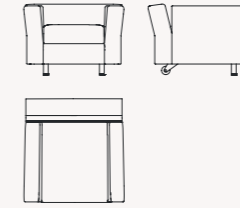

HW641

2-seater sofa/
Divano 2 posti

Length/
Lunghezza: 180 cm
Depth/
Profondità: 89 cm
Height/
Altezza: 60 cm

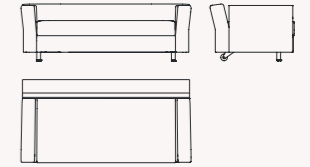

HW643

3-seater sofa/
Divano 3 posti

Length/
Lunghezza: 240 cm
Depth/
Profondità: 89 cm
Height/
Altezza: 60 cm

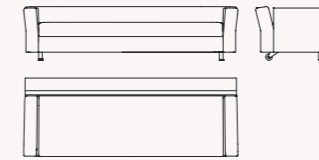

HW641

Cushion/
Cuscino

Length/
Lunghezza: 64 cm
Depth/
Profondità: 64 cm
Height/
Altezza: 12 cm

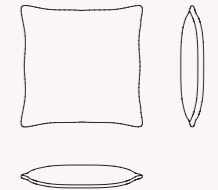

215

Finishes Finiture

Structure
Struttura



N - Ral 9005

CAPRI COLLECTION

Compasso D'oro
Honorable mention 1994



216



Hannes Wettstein 1990/1991

Caprichair, Caprilarge, Capri Jolly and Caprilarge Jolly are armchairs with reclining backrests and swivel casters. The Jolly versions have completely removable covers.

Caprichair is an object with a pure identity, embodying a clear, logical, and accessible design philosophy. Appearing simple at first glance, Caprichair reflects a precise function, with a lightness that conceals solid complexity. Its almost anthropomorphic shape invites interaction: it winks, moves, and transforms. Its language is dual, sometimes exuberant, other times natural, maintaining a constant dialogue with the surrounding space. Caprichair is part of a family that finds a home anywhere: from domestic interiors to workspaces, always serving creative freedom.

Caprichair, Caprilarge, Capri Jolly e Caprilarge Jolly sono poltrone con schienale reclinabile e ruote piroettanti. Le versioni Jolly sono completamente sfoderabili.

Caprichair è un oggetto dall'identità pura, espressione di un pensiero progettuale chiaro, logico, accessibile. Semplice solo in apparenza, Caprichair riflette una funzione precisa, con una leggerezza che nasconde una solida complessità. La forma, quasi antropomorfa, è un invito: ammicca, si muove, si trasforma. Il suo linguaggio è duplice, a volte esuberante, a volte naturale, in costante dialogo con lo spazio circostante. Caprichair è parte di una famiglia che trova casa ovunque: dagli interni domestici agli spazi di lavoro, sempre al servizio della libertà creativa.



217

PRODUCT FACT SHEET SCHEDA PRODOTTO

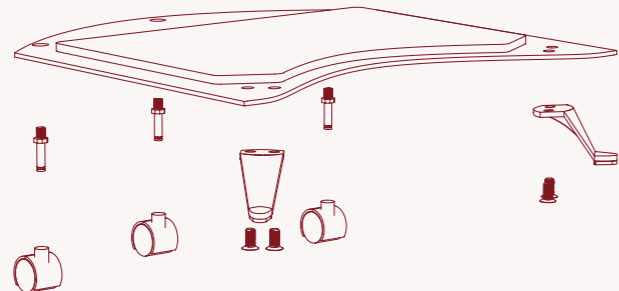
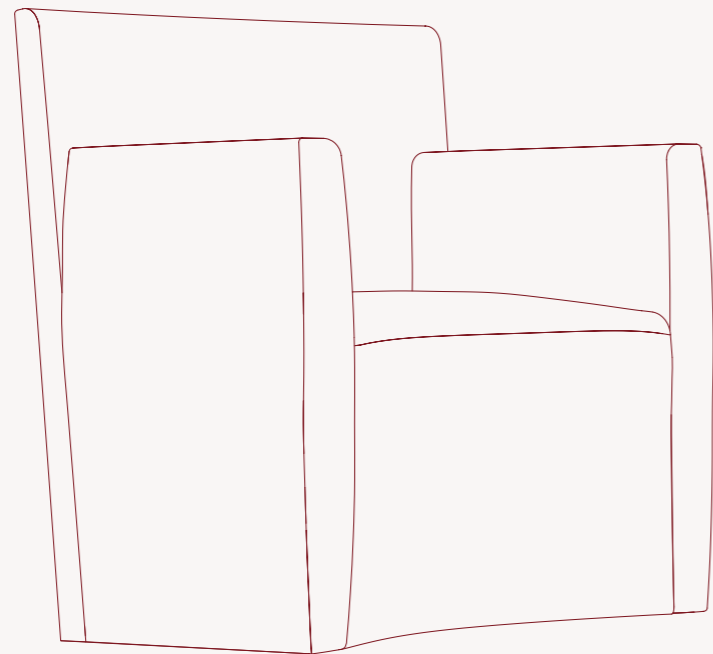

218

Dimensions Dimensioni

HW620

Armchair/
Poltrona

Length/
Lunghezza: 59 cm
Depth/
Profondità: 61 cm
Height/
Altezza: 81 cm

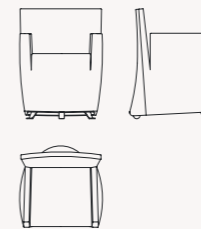

HW630

Armchair/
Poltrona

Length/
Lunghezza: 59 cm
Depth/
Profondità: 61 cm
Height/
Altezza: 81 cm

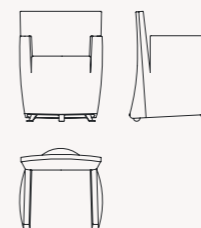

HW624

Armchair/
Poltrona

Length/
Lunghezza: 66 cm
Depth/
Profondità: 61 cm
Height/
Altezza: 81 cm

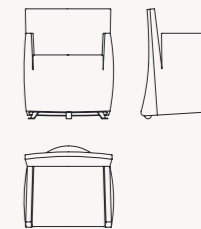

HW636

Armchair/
Poltrona

Length/
Lunghezza: 66 cm
Depth/
Profondità: 61 cm
Height/
Altezza: 81 cm

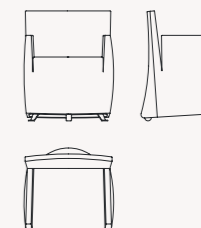

219

Technical description

Range of armchairs with reclining backrest.

Internal steel structure and flexible cold-foamed polyurethane padding.

Two front feet in satin-finish die-cast aluminum.

Five or three swivel rear wheels in polyurethane-coated rubber.

Upholstery in fabric, technical fabric, leather, eco-leather, customer's leather (pc) or customer's fabric (tc), fixed or completely removable.

Descrizione tecnica

Sistema di poltrone con schienale reclinabile.

Struttura interna in acciaio e imbottitura in poliuretano flessibile schiumato a freddo.

Due piedini di appoggio anteriori in pressofusione in alluminio satinato.

Cinque o tre ruote piroettanti posteriori in gomma rivestite in poliuretano.

Rivestimento in tessuto, tessuto tecnico, pelle, ecopelle, pelle cliente (pc) o tessuto cliente (tc), fisso o completamente sfoderabile.

JULIETTE



220

Hannes Wettstein 1987

Juliette is a range of seats made entirely of recyclable metal, available in seven colors or in a satin finished stainless steel version that can also be used outdoors. The chair is stackable and saves space when not in use.

From the lively and creative mind of Hannes Wettstein comes an idea that defies logic: a chair whose backrest, bent forward for purely aesthetic reasons, becomes a functional element. In the industrial process, the backrest evolves into an armrest, transforming the chair into an armchair. This 'super-light' chair, made of nothing and carefully studied details, surprises with its unexpected comfort. An object that is the expression of a design that is both pragmatic and utopian: unobtrusive and non-obsolescent.



Juliette è un sistema di sedute completamente disassemblabili, realizzate interamente in metallo riciclabile. È disponibile in sette colori, oppure in una versione in acciaio inox satinato utilizzabile anche in outdoor. La sedia è impilabile e permette di risparmiare spazio quando non è in uso.

Dalla mente vivace e creativa di Hannes Wettstein, prende forma un'idea che sfida la logica: una sedia il cui schienale, piegato in avanti per una scelta puramente estetica, diventa un elemento funzionale. Nel processo industriale, lo schienale evolve in bracciolo, trasformando la sedia in una poltroncina. Questa 'superleggera,' fatta di niente e di dettagli studiati, stupisce per il suo comfort inaspettato. Un oggetto che è espressione di un design pragmatico e al tempo stesso utopico: non appariscente e non obsolecente.

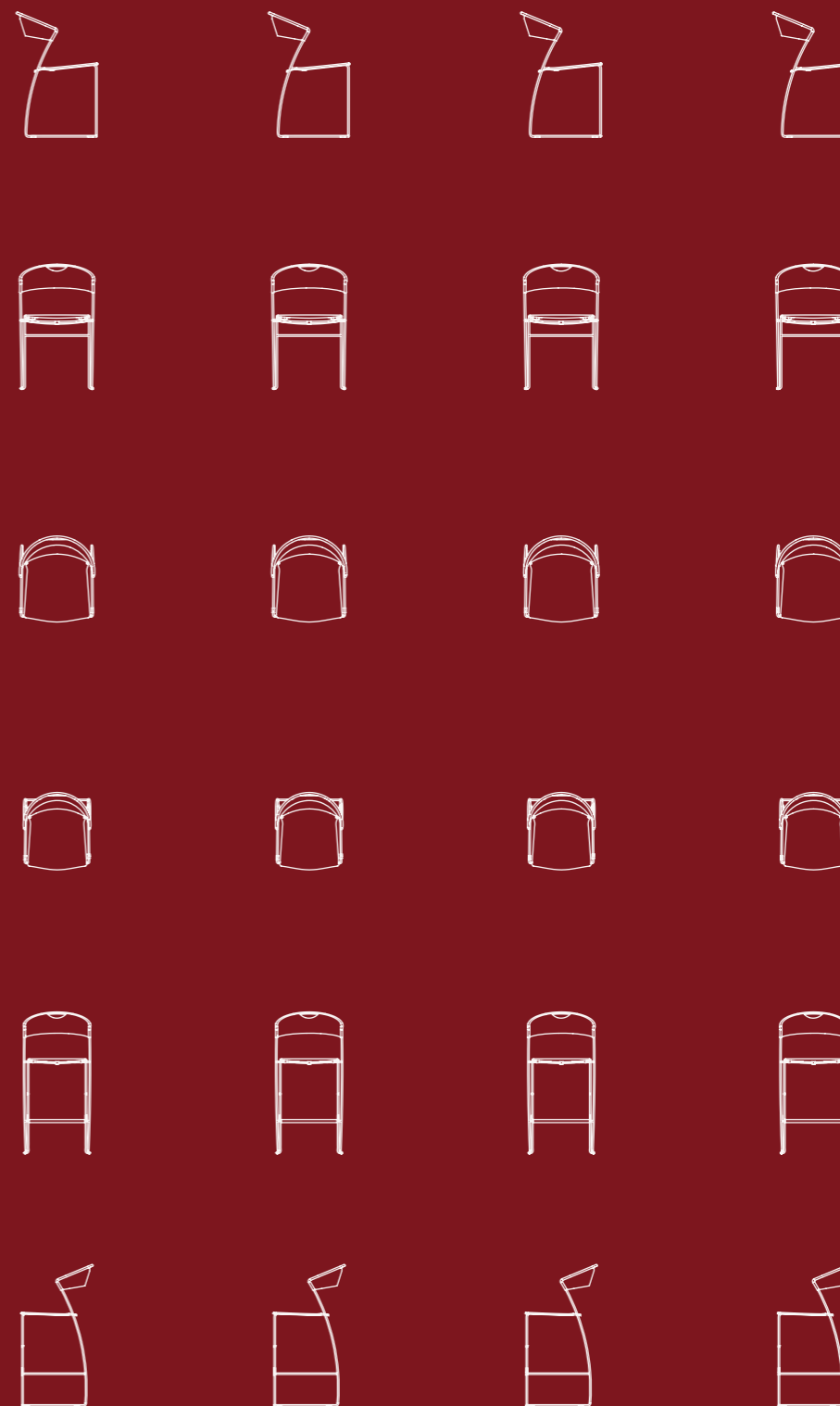

221

PRODUCT FACT SHEET SCHEDA PRODOTTO

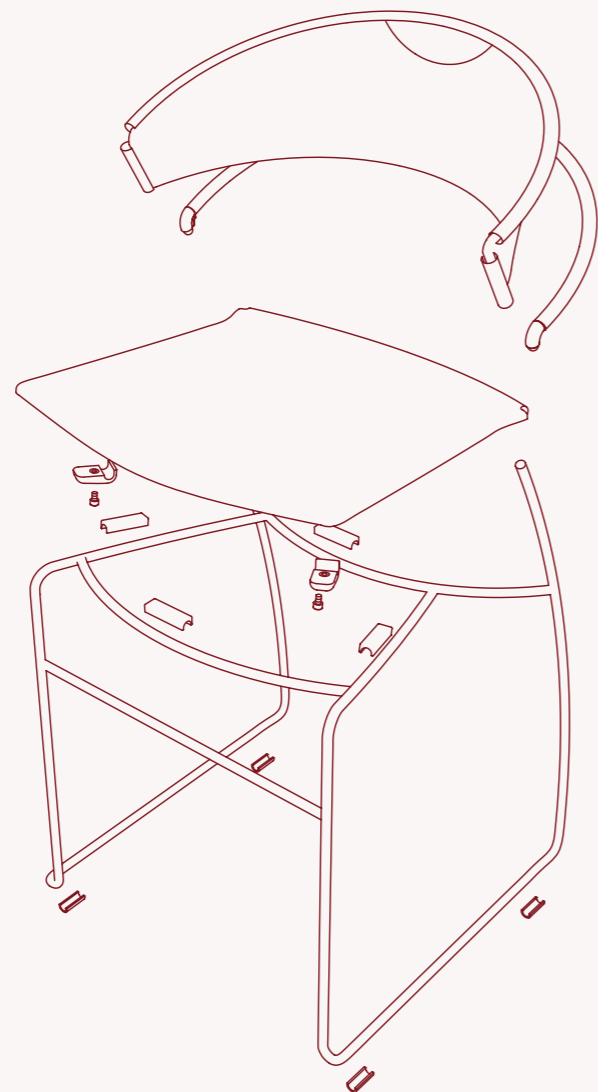

222

Technical description

Range of stackable seats with structure made of steel rod.

Painted with epoxy powders in the specified colours.

Seat and backrest of stamped sheet steel painted in the color of the structure.

Alternatively, structure, seat and backrest in satinated stainless steel.

Black polyethylene interlocking feet.

Available accessories: covers, black rubber connecting element.

Descrizione tecnica

Sistema di sedute impilabili con struttura in tondino di acciaio.

Verniciatura con polveri epossidiche nei colori indicati.

Sedile e schienale in lamiera d'acciaio stampata e verniciata nel colore della struttura.

In alternativa, struttura, sedile e schienale in acciaio inox satinato.

Piedini ad incastro in polietilene nero.

Accessori disponibili: fodere, elemento di collegamento in gomma nera.

Dimensions Dimensioni

HW601

Stackable chair/
Sedia impilabile

Length/
Lunghezza: 46 cm
Depth/
Profondità: 50 cm
Height/
Altezza: 77 cm



HW608

Kitchen stool/
Sgabello da cucina

Length/
Lunghezza: 46 cm
Depth/
Profondità: 50 cm
Height/
Altezza: 97 cm

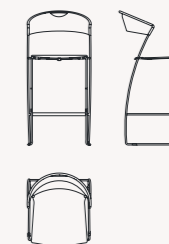

HW609

Bar stool/
Sgabello bar

Length/
Lunghezza: 46 cm
Depth/
Profondità: 50 cm
Height/
Altezza: 110 cm

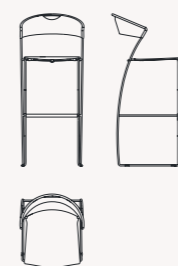

223

Finishes Finiture

Structure
Struttura



AM - Ral 9006

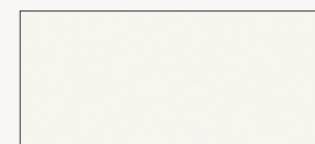

W - Ral 9010



GN - Ral 7021



N - Ral 9005

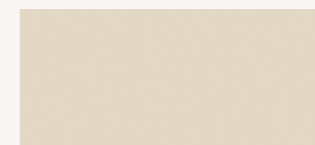

OW - Ral 1013



RR - Ral 3003



VO - Ral 6003

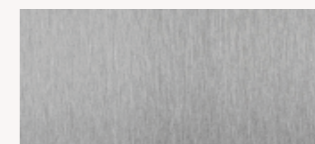

IX - Inox

INDEX INDICE

Upholsteries
Rivestimenti

Fabric/Tessuto

Plain	227
Torino	227
Linosa	228
Trofeo	229
Chenille/Ciniglia	230
Skorpios	230
Lucrezia	231
Ollin	232
Textured/Strutturato	233
New Manhattan	233
Samar	234
Bouclé	235
Fiocco	235
Marmolada	236
Brionne	237
Velvet/Velluto	238
Floki	238
Lario	239
Wool/Lana	240
Focus	240
Focus Melange	241
Wolin	242
Tato Collection	243
Vita Touch	243
Alabama	244
Leather/Pelle	
Leather/Pelle	245
Brezza	245
Diamante	246
Eco-Leather/Eco-Pelle	247
Extrema	247
Luna	248

Torino

Cat. A



Technical features

Fabric
Plain

Composition
100% Polyester

Weight
365 g/m²

Height
140 cm

Country of origin
Italy

Martindale abrasion
70.000

Pilling (ISO 12945-2)
5

Certifications
Oeko Tex Standard 100
IMO Med

Flammability test
BS 5852 Crib 5;
UNI 9175 Class 1IM;
BS 7176 Medium Hazard

Caratteristiche tecniche

Tessuto
Plain

Composizione
100% Poliestere

Peso
365 g/m²

Altezza
140 cm

Paese di origine
Italia

Abrasiono Martindale
70.000

Pilling (ISO 12945-2)
5

Certificazioni
Oeko Tex Standard 100
IMO Med

Test di infiammabilità
BS 5852 Crib 5;
UNI 9175 Class 1IM;
BS 7176 Medium Hazard

Washing instructions Istruzioni di lavaggio



Colours Colori



Linosa

Cat. A



Technical features

Fabric
Plain
Composition
100% Recycled cotton
Weight
600 g/m²
Height
140 cm
Country of origin
Italy

Martindale abrasion
25.000
Pilling (ISO 12945-2)
4
Certifications
Oeko Tex Standard 100
Global Recycled Standard:
100% Recycled
100% Biodegradable

Caratteristiche tecniche

Tessuto
Plain
Composizione
100% Cotone riciclato
Peso
600 g/m²
Altezza
140 cm
Paese di origine
Italia

Abrasione Martindale
25.000
Pilling (ISO 12945-2)
4
Certificazioni
Oeko Tex Standard 100
Global Recycled Standard:
100% Riciclato
100% Biodegradabile

Washing instructions Istruzioni di lavaggio



228

Colours Colori

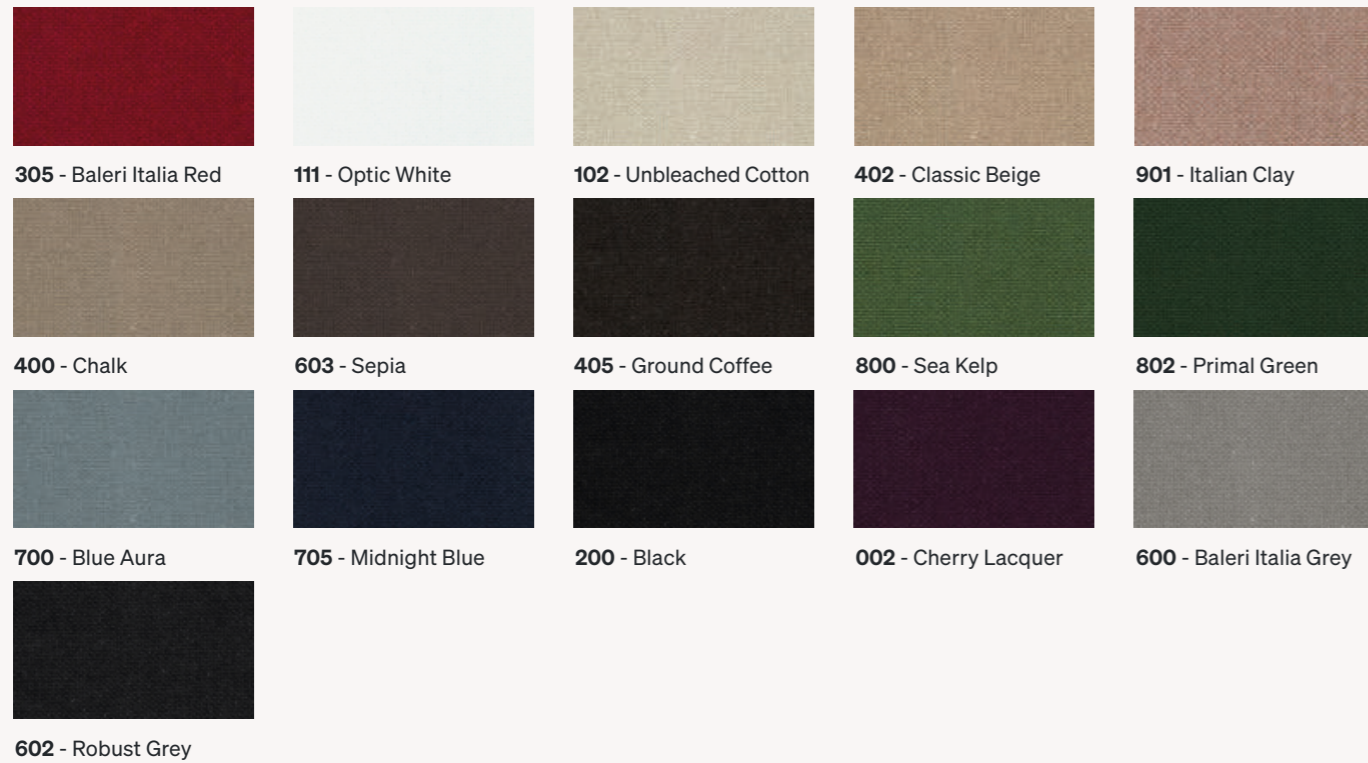

Trofeo

Cat. D



Technical features

Fabric
Plain
Composition
100% Linen
Weight
810 g/m²
Height
140 cm
Country of origin
Italy

Martindale abrasion
15.000
Flammability test
TB 117;
BS 5852-1 Cigarette

Caratteristiche tecniche

Tessuto
Plain
Composizione
100% Lino
Peso
810 g/m²
Altezza
140 cm
Paese di origine
Italia

Abrasione Martindale
15.000
Test di infiammabilità
TB 117;
BS 5852-1 Cigarette

Washing instructions Istruzioni di lavaggio



229

Colours Colori

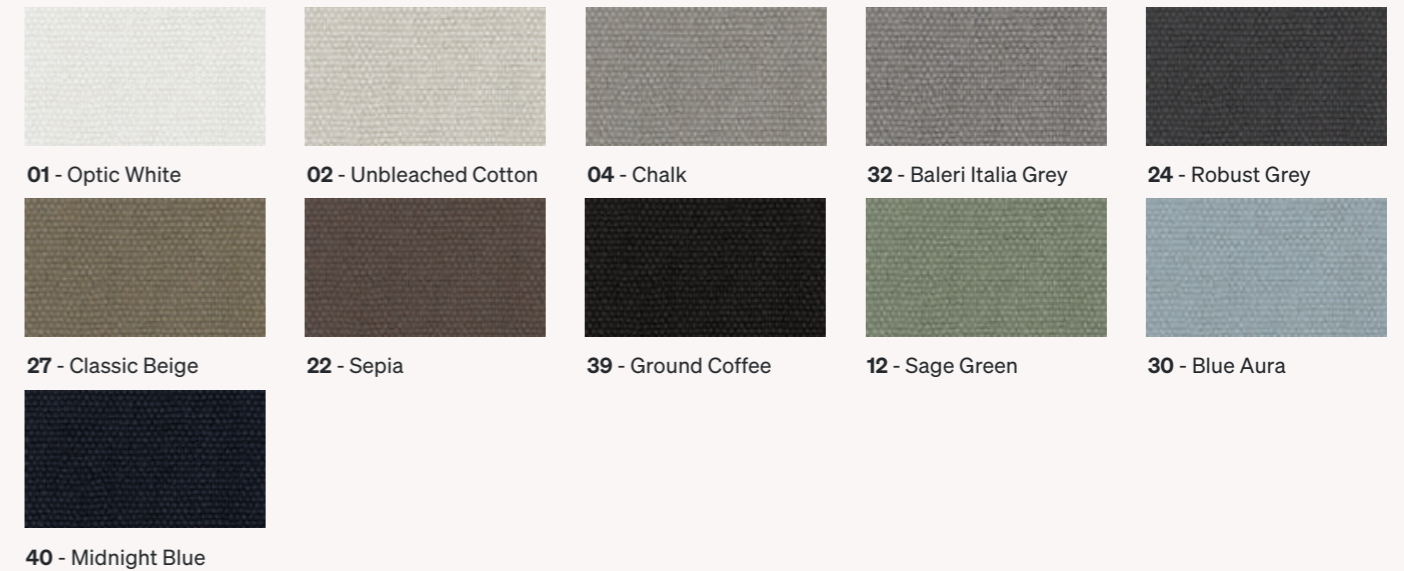

Skorpios

Cat. A

Technical features

Fabric
Chenille

Composition
100% Polyester

Weight
725 g/m²

Height
140 cm

Country of origin
Italy

Martindale abrasion
50.000

Flammability test
TB 117

Caratteristiche tecniche

Tessuto
Ciniglia

Composizione
100% Poliestere

Peso
725 g/m²

Altezza
140 cm

Paese di origine
Italia

Abrasione Martindale
50.000

Test di infiammabilità
TB 117

Washing instructions Istruzioni di lavaggio



230

Colours Colori

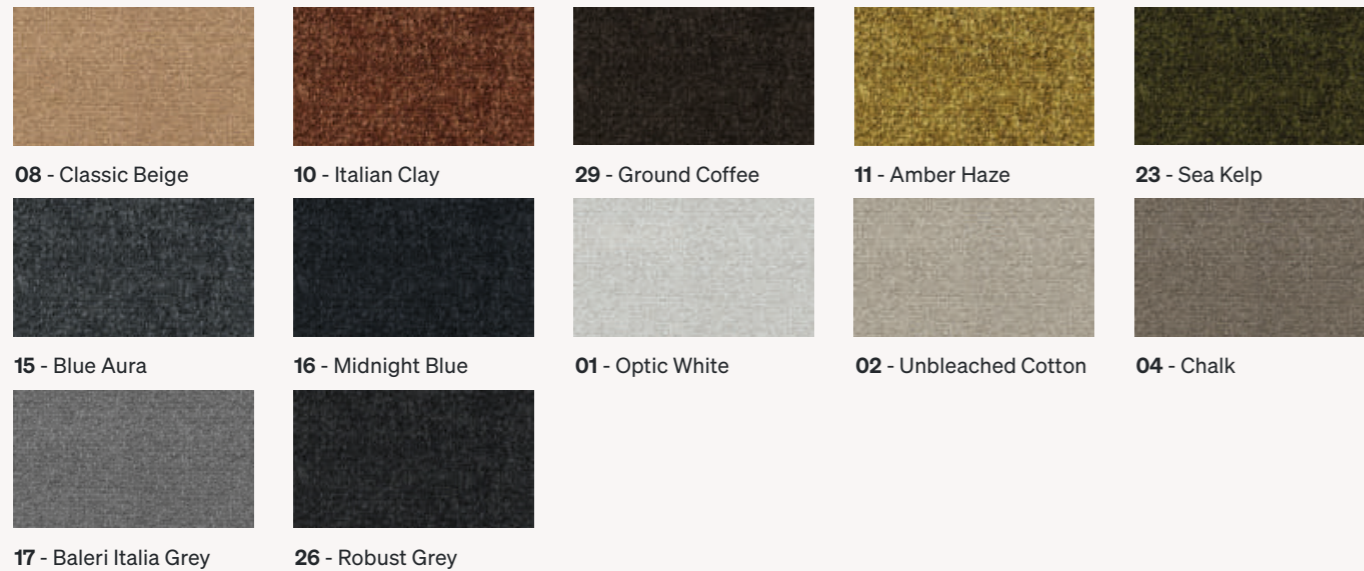

Lucrezia

Cat. B



Technical features

Fabric
Chenille

Composition
44% Viscose;
28% Cotton;
15% Linen;
13% Polyester

Weight
680 g/m²

Height
140 cm

Country of origin
Italy

Martindale abrasion
37.000

Pilling (ISO 12945-2)
3

Flammability test
BS 5852-0 Cigarette

Caratteristiche tecniche

Tessuto
Ciniglia

Composizione
44% Viscosa;
28% Cotone;
15% Lino;
13% Poliestere

Peso
680 g/m²

Altezza
140 cm

Paese di origine
Italia

Abrasione Martindale
37.000

Pilling (ISO 12945-2)
3

Test di infiammabilità
BS 5852-0 Cigarette

Washing instructions Istruzioni di lavaggio



231

Colours Colori



Ollin

Cat. C



Technical features

Fabric
Chenille

Composition
55% Cotton;
45% Viscose

Weight
770 g/m²

Height
140 cm

Country of origin
Italy

Martindale abrasion
25.000

Pilling (ISO 12945-2)
4

Flammability test
BS 5852-0 Cigarette

Caratteristiche tecniche

Tessuto
Ciniglia

Composizione
55% Cotone;
45% Viscosa

Peso
770 g/m²

Altezza
140 cm

Paese di origine
Italia

Abrasione Martindale
25.000

Pilling (ISO 12945-2)
4

Test di infiammabilità
BS 5852-0 Cigarette

Washing instructions Istruzioni di lavaggio



232

Colours Colori



New Manhattan

Cat. A



Technical features

Fabric
Textured

Composition
95% Polyester;
5% Linen

Weight
950 g/m²

Height
140 cm

Country of origin
Italy

Martindale abrasion
40.000

Pilling (ISO 12945-2)
4

Certifications
Oeko Tex Standard 100

Flammability test
TB 117;
BS 5852-1 Cigarette

Caratteristiche tecniche

Tessuto
Strutturato

Composizione
95% Poliestere;
5% Lino

Peso
950 g/m²

Altezza
140 cm

Paese di origine
Italia

Abrasione Martindale
40.000

Pilling (ISO 12945-2)
4

Certifications
Oeko Tex Standard 100

Test di infiammabilità
TB 117;
BS 5852-1 Cigarette

Washing instructions Istruzioni di lavaggio



233

Colours Colori



Samar

Cat. B



Technical features

Fabric
Textured

Composition
73% Recycled polyester;
27% Polyester

Weight
663 g/m²

Height
140 cm

Country of origin
Italy

Martindale abrasion
50.000

Pilling (ISO 12945-2)
5

Certifications
Oeko Tex Standard 100
IMO Med

Flammability test
BS 5852 Crib 5;
UNI 9175 Class 1IM

Caratteristiche tecniche

Tessuto
Strutturato

Composizione
73% Poliestere riciclato;
27% Poliestere

Peso
663 g/m²

Altezza
140 cm

Paese di origine
Italia

Abrasione Martindale
50.000

Pilling (ISO 12945-2)
5

Certificazioni
Oeko Tex Standard 100
IMO Med

Test di infiammabilità
BS 5852 Crib 5;
UNI 9175 Class 1IM

Washing instructions Istruzioni di lavaggio



234

Colours Colori

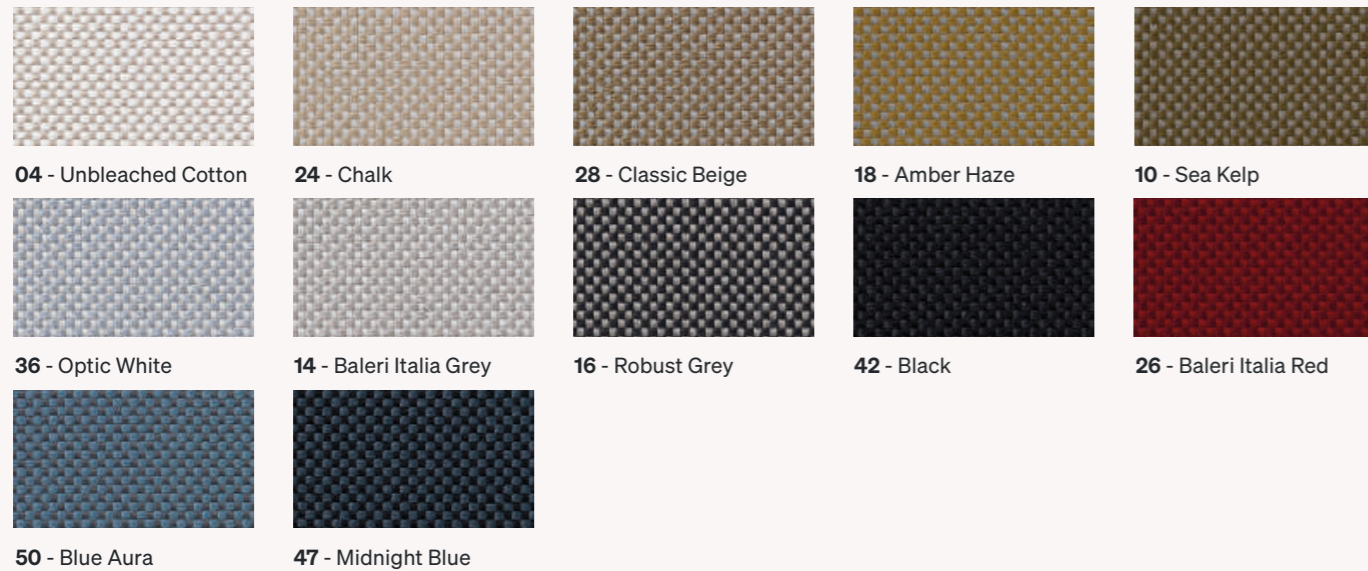

Fiocco

Cat. B



Technical features

Fabric
Bouclé

Composition
100% Polyester

Weight
620 g/m²

Height
140 cm

Country of origin
Italy

Martindale abrasion
60.000

Pilling (ISO 12945-2)
5

Certifications
Oeko Tex Standard 100
IMO Med

Flammability test
BS 5852 Crib 5;
UNI 9175 Class 1IM;
BS 7176 Medium Hazard

Caratteristiche tecniche

Tessuto
Bouclé

Composizione
100% Poliestere

Peso
620 g/m²

Altezza
140 cm

Paese di origine
Italia

Abrasione Martindale
60.000

Pilling (ISO 12945-2)
5

Certificazioni
Oeko Tex Standard 100
IMO Med

Test di infiammabilità
BS 5852 Crib 5;
UNI 9175 Class 1IM;
BS 7176 Medium Hazard

Washing instructions Istruzioni di lavaggio



235

Colours Colori

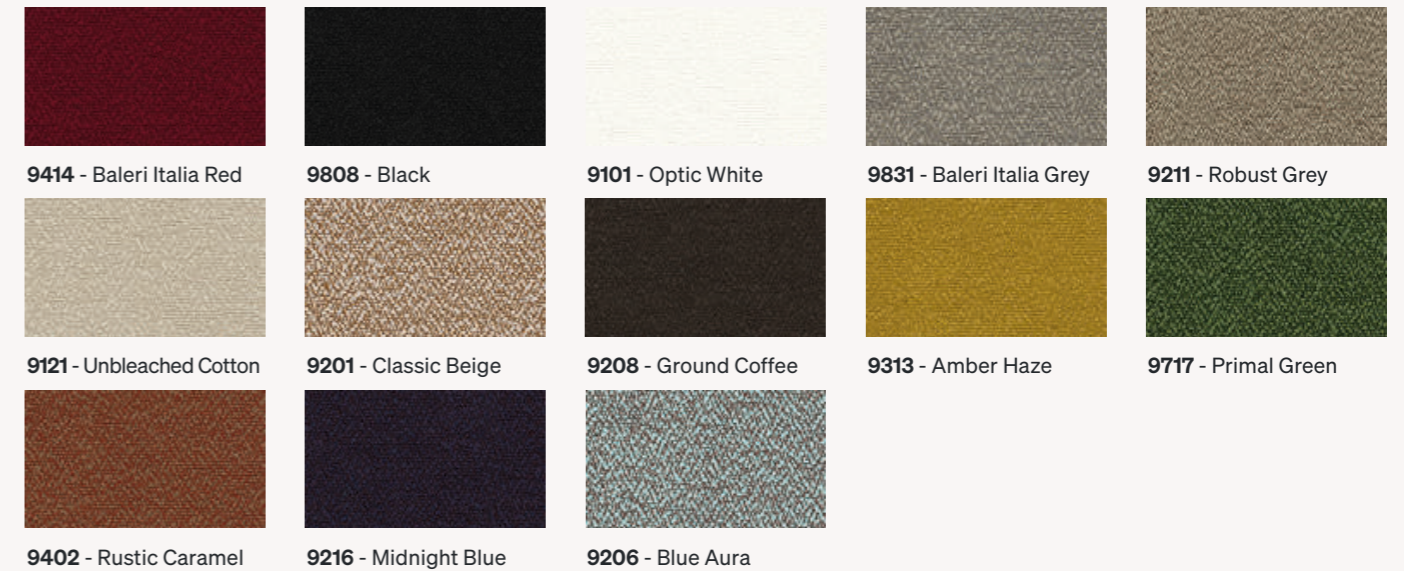

Marmolada

Cat. C



Technical features

Fabric

Bouclé

Composition

29% Polyester;
25% Acrylic;
25% Wool;
21% Cotton

Weight

720 g/m²

Height

138 cm

Country of origin

Italy

Martindale abrasion

40.000

Pilling (ISO 12945-2)

4

Flammability test

TB 117;
BS 5852-0 Cigarette

Caratteristiche tecniche

Tessuto

Bouclé

Composizione

29% Poliestere;
25% Acrilico;
25% Lana;
21% Cotone

Peso

720 g/m²

Altezza

138 cm

Paese di origine

Italia

Abrasione Martindale

40.000

Pilling (ISO 12945-2)

4

Test di infiammabilità

TB 117;
BS 5852-0 Cigarette

Washing instructions Istruzioni di lavaggio



236

Colours Colori

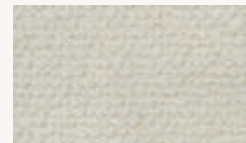

01 - Optic White



02 - Baleri Italia Grey

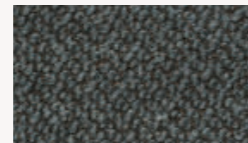

22 - Robust Grey

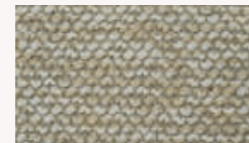

03 - Unbleached Cotton



30 - Chalk



09 - Sepia



19 - Ground Coffee



25 - Amber Haze

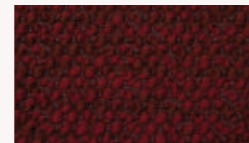

10 - Baleri Italia Red



26 - Primal Green

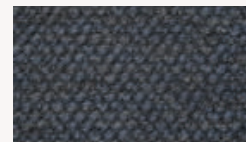

07 - Blue Aura

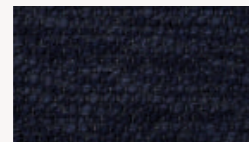

11 - Midnight Blue



15 - Black

Brionne

Cat. C



Technical features

Fabric

Bouclé

Composition

31% Polyester;
26% Wool;
22% Acrylic;
18% Cotton;
3% Polyamide

Weight

740 g/m²

Height

140 cm

Country of origin

Italy

Martindale abrasion

40.000

Pilling (ISO 12945-2)

4

Flammability test

TB 117;
BS 5852-1 Cigarette

Caratteristiche tecniche

Tessuto

Bouclé

Composizione

31% Poliestere;
26% Lana;
22% Acrilico;
18% Cotone;
3% Poliammide

Peso

740 g/m²

Altezza

140 cm

Paese di origine

Italia

Abrasione Martindale

40.000

Pilling (ISO 12945-2)

4

Test di infiammabilità

TB 117;
BS 5852-1 Cigarette

Washing instructions Istruzioni di lavaggio



237

Colours Colori

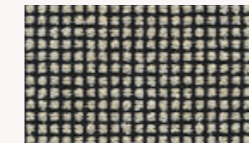

040 - Black and White

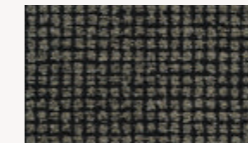

124 - Black and Grey



041 - Black

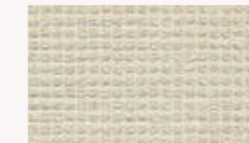

010 - Optic White

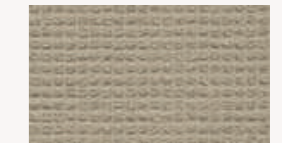

020 - Unbleached Cotton



000 - Chalk

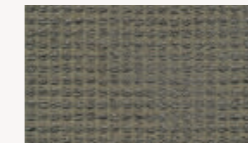

001 - Baleri Italia Grey



031 - Midnight Blue

Floki

Cat. C



Technical features

Fabric
Velvet

Composition
100% Recycled polyester

Weight
590 g/m²

Height
140 cm

Country of origin
Italy

Martindale abrasion
100.000

Pilling (ISO 12945-2)
4

Flammability test
TB 117;
BS 5852-1 Cigarette

Caratteristiche tecniche

Tessuto
Velluto

Composizione
100% Poliestere riciclato

Peso
590 g/m²

Altezza
140 cm

Paese di origine
Italia

Abrasione Martindale
100.000

Pilling (ISO 12945-2)
4

Test di infiammabilità
TB 117;
BS 5852-1 Cigarette

Washing instructions Istruzioni di lavaggio



238

Colours Colori

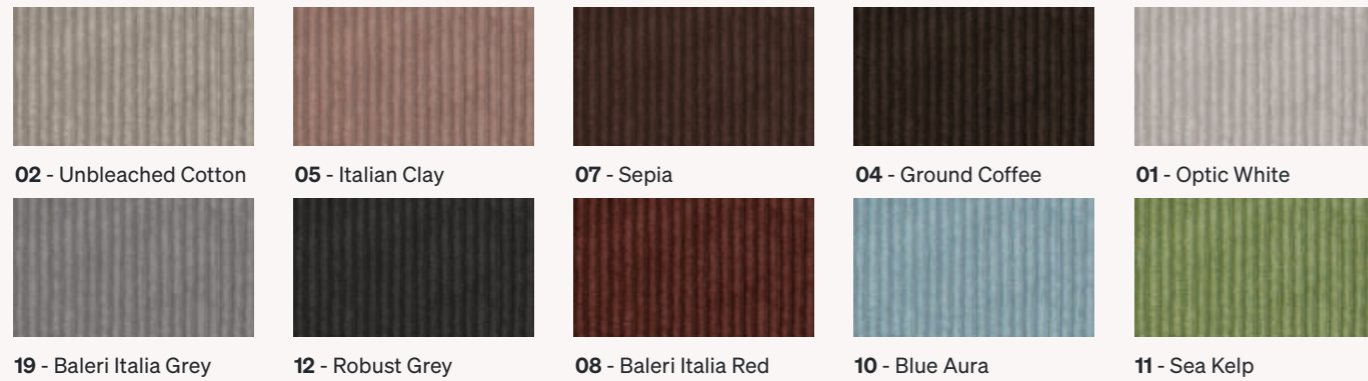

Lario

Cat. D



Technical features

Fabric
Velvet

Composition
100% Cotton

Weight
728 g/m²

Height
140 cm

Country of origin
Italy

Martindale abrasion
80.000

Pilling (ISO 12945-2)
5

Certifications
Oeko Tex Standard 100

Flammability test
TB 117

Caratteristiche tecniche

Tessuto
Velluto

Composizione
100% Cotone

Peso
728 g/m²

Altezza
140 cm

Paese di origine
Italia

Abrasione Martindale
80.000

Pilling (ISO 12945-2)
5

Certificazioni
Oeko Tex Standard 100

Test di infiammabilità
TB 117

Washing instructions Istruzioni di lavaggio



239

Colours Colori



Focus

Cat. B



Technical features

Fabric
Wool

Composition
100% Wool

Weight
660 g/m²

Height
140 cm

Country of origin
New Zeland

Martindale abrasion
100.000

Pilling (ISO 12945-2)
4

Certifications
Oeko Tex Standard 100
100% recyclable - EU Ecolabel
Certificate

Flammability test
TB 117;
BS 5852-1 Cigarette;
UNI 9175 Class 1IM

Caratteristiche tecniche

Tessuto
Lana

Composizione
100% Lana

Peso
660 g/m²

Altezza
140 cm

Paese di origine
Nuova Zelanda

Abrasione Martindale
100.000

Pilling (ISO 12945-2)
4

Certificazioni
Oeko Tex Standard 100
100% riciclabile - EU Ecolabel
Certificate

Test di infiammabilità
TB 117;
BS 5852-1 Cigarette;
UNI 9175 Class 1IM

Washing instructions Istruzioni di lavaggio



240

Colours Colori

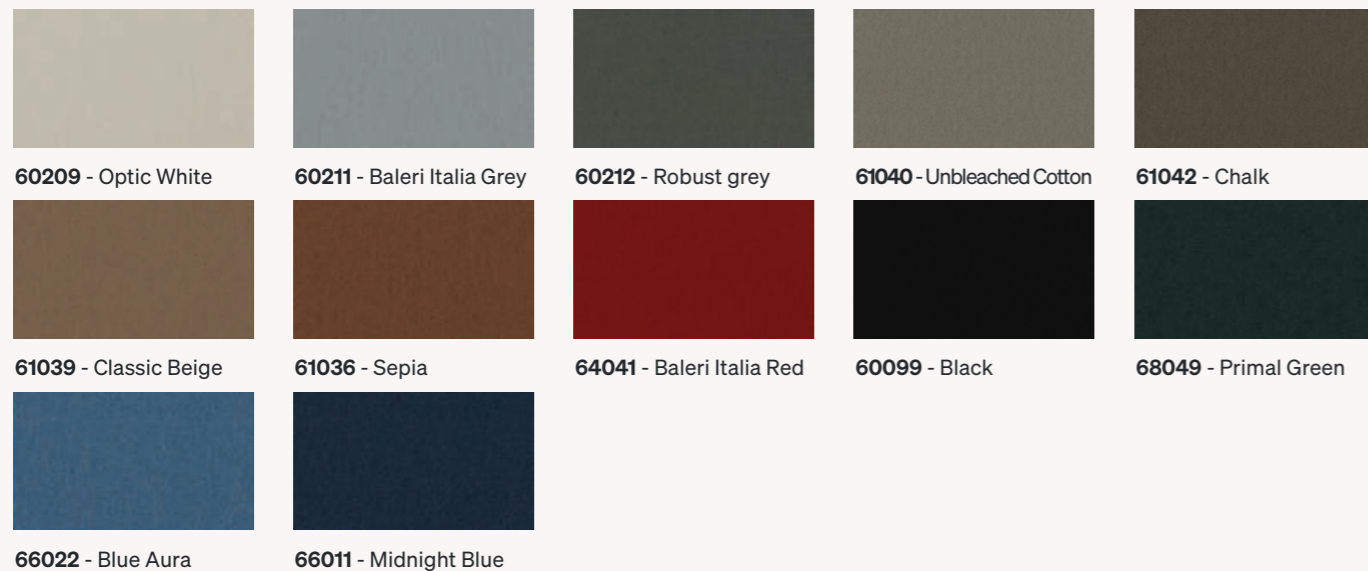

Focus Melange

Cat. B



Technical features

Fabric
Wool

Composition
100% Wool

Weight
660 g/m²

Height
140 cm

Country of origin
New Zeland

Martindale abrasion
100.000

Pilling (ISO 12945-2)
4

Certifications
Oeko Tex Standard 100
100% recyclable - EU Ecolabel
Certificate

Flammability test
TB 117;
BS 5852-1 Cigarette;
UNI 9175 Class 1IM

Caratteristiche tecniche

Tessuto
Lana

Composizione
100% Lana

Peso
660 g/m²

Altezza
140 cm

Paese di origine
Nuova Zelanda

Abrasione Martindale
100.000

Pilling (ISO 12945-2)
4

Certificazioni
Oeko Tex Standard 100
100% riciclabile - EU Ecolabel
Certificate

Test di infiammabilità
TB 117;
BS 5852-1 Cigarette;
UNI 9175 Class 1IM

Washing instructions Istruzioni di lavaggio



241

Colours Colori

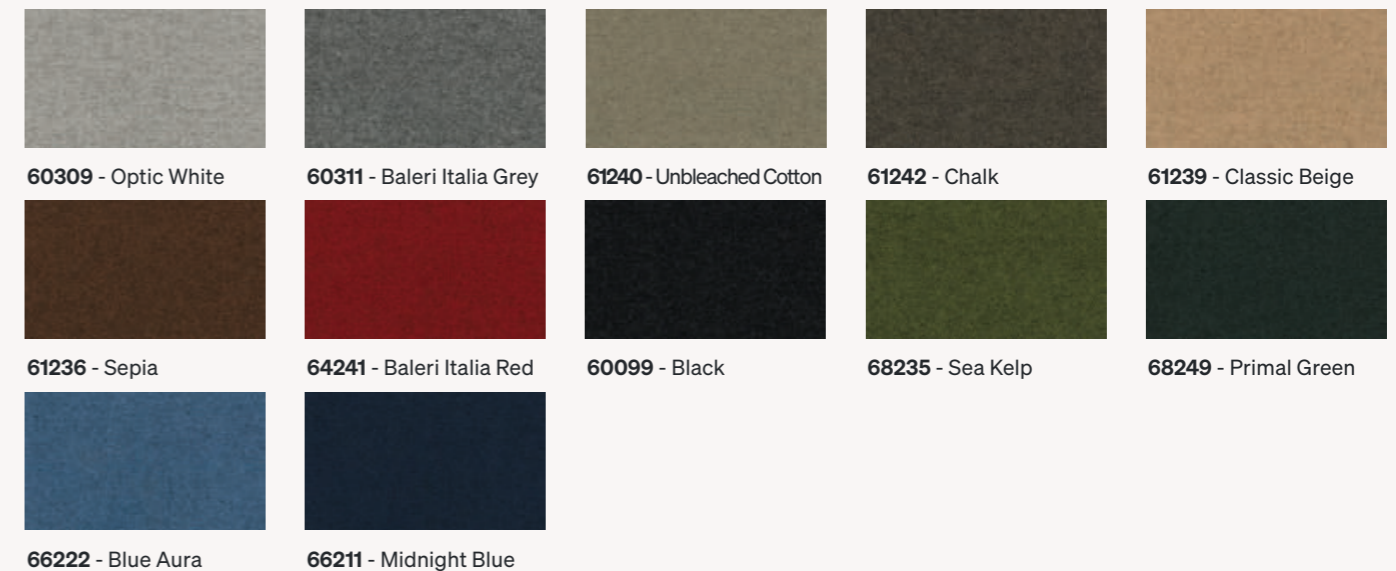

Wolin

Cat. D



Technical features

Fabric
Wool

Composition
75% Recycled wool;
20% Polyester;
5% Polyamide

Weight
638 g/m²

Height
150 cm

Country of origin
Italy

Martindale abrasion
100.000

Pilling (ISO 12945-2)
4

Certifications
Oeko Tex Standard 100
IMO Med

Flammability test
TB 117;
BS 5852-1 Cigarette;
UNI 9175 Class 1IM

Caratteristiche tecniche

Tessuto
Lana

Composizione
75% Lana riciclata;
20% Poliestere;
5% Poliammide

Peso
638 g/m²

Altezza
150 cm

Paese di origine
Italia

Abrasiono Martindale
100.000

Pilling (ISO 12945-2)
4

Certificazioni
Oeko Tex Standard 100
IMO Med

Test di infiammabilità
TB 117;
BS 5852-1 Cigarette;
UNI 9175 Class 1IM

Washing instructions Istruzioni di lavaggio



242

Colours Colori

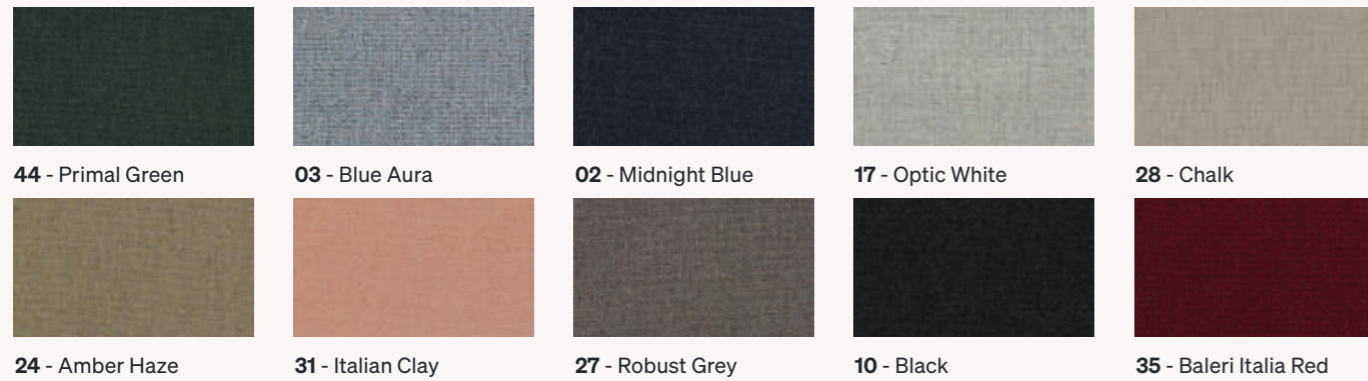

Vita Touch

Cat. A



Technical features

Fabric
Tato Collection

Composition
78% Recycled polyamide;
22% Elastane

Weight
323 g/m²

Height
150 cm

Country of origin
Italy

Martindale abrasion
20.000

Pilling (ISO 12945-2)
4

Certifications
Oeko Tex Standard 100

Caratteristiche tecniche

Tessuto
Tato Collection

Composizione
78% Poliammide riciclato;
22% Elastan

Peso
323 g/m²

Altezza
150 cm

Paese di origine
Italia

Abrasiono Martindale
20.000

Pilling (ISO 12945-2)
4

Certificazioni
Oeko Tex Standard 100

Washing instructions Istruzioni di lavaggio



243

Colours Colori



Alabama

Cat. B



Technical features

Fabric
Tato Collection
Composition
91% Polyester;
9% Elastane
Weight
395 g/m²
Height
152 cm
Country of origin
Italy

Martindale abrasion
40.000
Pilling (ISO 12945-2)
5
Flammability test
TB 117;
BS 5852-1 Cigarette;
UNI 9175 Class 1IM

Caratteristiche tecniche

Tessuto
Tato Collection
Composizione
91% Poliestere;
9% Elastan
Peso
395 g/m²
Altezza
152 cm
Paese di origine
Italia

Abrasione Martindale
40.000
Pilling (ISO 12945-2)
5
Test di infiammabilità
TB 117;
BS 5852-1 Cigarette;
UNI 9175 Class 1IM

Washing instructions Istruzioni di lavaggio



244

Colours Colori



Brezza

Cat. E



Technical features

Leather
Leather
Composition
100% European bovine
Min. thickness
0.9 mm
Max. thickness
1.1 mm
Height
5 mq

Certifications
IMO MED FTP8
Flammability test
TB 117;
BS 5852-0 Cigarette

Caratteristiche tecniche

Pelle
Pelle
Composizione
100% Bovino europeo
Spessore min.
0.9 mm
Spessore max.
1.1 mm
Altezza
5 mq

Certificazioni
IMO MED FTP8
Test di infiammabilità
TB 117;
BS 5852-0 Cigarette

Washing instructions Istruzioni di lavaggio



245

Colours Colori



Diamante

Cat. E



Technical features

Leather
Leather

Composition
100% European bovine

Min. thickness
1.3 mm

Max. thickness
1.5 mm

Height
5 mq

Flammability test
TB 117;

BS 5852-0 Cigarette

Caratteristiche tecniche

Pelle
Pelle

Composizione
100% Bovino europeo

Spessore min.
1.3 mm

Spessore max.
1.5 mm

Altezza
5 mq

Test di infiammabilità
TB 117;

BS 5852-0 Cigarette

Washing instructions Istruzioni di lavaggio



246

Colours Colori

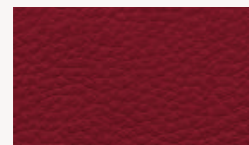

7820 - Baleri Italia Red

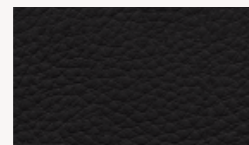

800 - Black

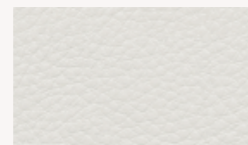

871 - Optic White

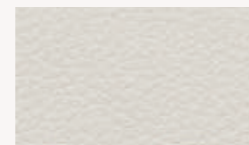

870 - Off White



7208 - Baleri Italia Grey

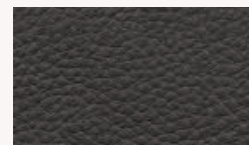

815 - Robust Grey

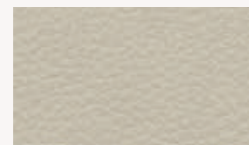

7831 - Unbleached Cotton

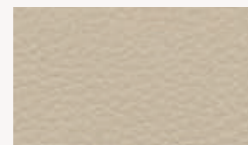

7206 - Chalk



7254 - Classic Beige



7218 - Italian Clay



7057 - Sepia

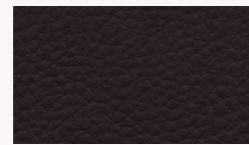

7815 - Ground Coffee



7258 - Amber Haze



7264 - Sea Kelp

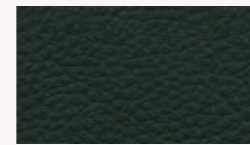

7817 - Primal Green



7232 - Blue Aura

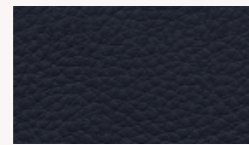

898 - Midnight Blue



818 - Cannella

Extrema

Cat. B



Technical features

Leather
Eco-leather

Composition
63% Polyurethane;
29% Cotton;
8% Polyester

Weight
480 g/m²

Height
140 cm

Country of origin
Italy

Martindale abrasion
150.000

Flammability test
BS 5852 Crib 5;
UNI 9175 Class 1IM

Caratteristiche tecniche

Pelle
Eco-pelle

Composizione
63% Poliuretano;
29% Cotone;
8% Poliestere

Peso
480 g/m²

Altezza
140 cm

Paese di origine
Italia

Abrasione Martindale
150.000

Test di infiammabilità
BS 5852 Crib 5;
UNI 9175 Class 1IM

Washing instructions Istruzioni di lavaggio



247

Colours Colori



850 - Baleri Italia Red

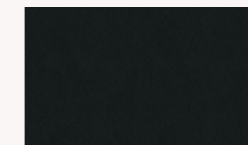

2250 - Black

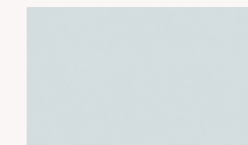

150 - Optic White

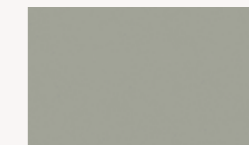

3750 - Chalk



4450 - Baleri Italia Grey

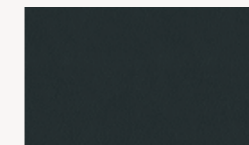

2150 - Robust Grey

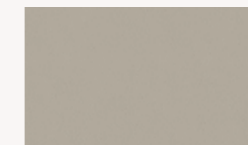

250 - Unbleached Cotton



350 - Classic Beige

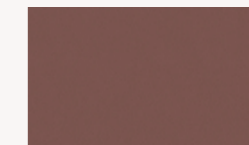

4050 - Italian Clay



1250 - Sepia



1350 - Ground Coffee



650 - Amber Haze



2450 - Sea Kelp



1550 - Primal Green



1750 - Blue Aura



1950 - Midnight Blue



1150 - Siena



1050 - Melograno

Luna

Cat. C



Technical features

Leather

Eco-leather

Composition

100% Polyester

Weight

520 g/m²

Height

140 cm

Country of origin

Italy

Martindale abrasion

40.000

Pilling (ISO 12945-2)

5

Flammability test

TB 117;

BS 5852-0 Cigarette

Caratteristiche tecniche

Pelle

Eco-pelle

Composizione

100% Poliestere

Peso

520 g/m²

Altezza

140 cm

Paese di origine

Italia

Abrasione Martindale

40.000

Pilling (ISO 12945-2)

5

Test di infiammabilità

TB 117;

BS 5852-0 Cigarette

Washing instructions Istruzioni di lavaggio



248

Colours Colori

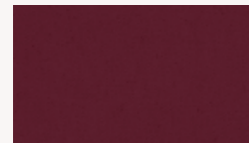

1213 - Baleri Italia Red

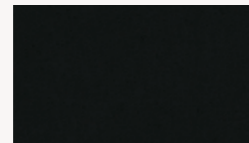

1201 - Black

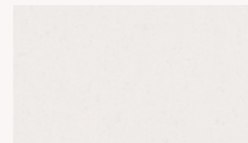

1240 - Optic White



1245 - Chalk

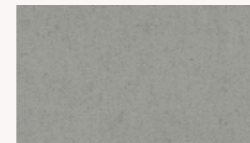

1252 - Baleri Italia Grey

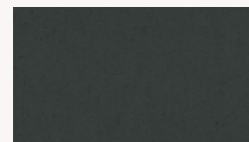

1253 - Robust Grey

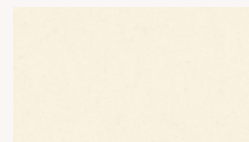

1239 - Unbleached Cotton

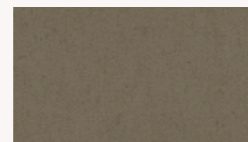

1249 - Classic Beige

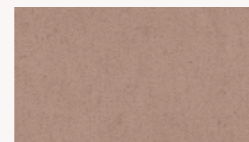

1265 - Italian Clay

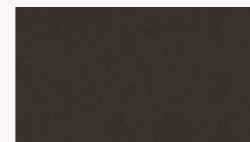

1250 - Sepia

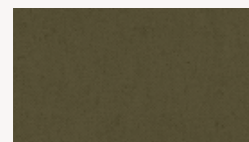

1274 - Amber Haze

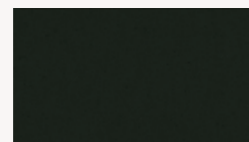

1279 - Primal Green

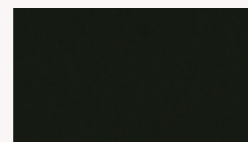

1283 - Sea Kelp



1286 - Blue Aura



1290 - Midnight Blue



1261 - Rustic Caramel

Disclaimer

Baleri Italia reserves the rights to make any modifications of parts or details considered necessary with the aim of making improvements or for any other requirements of a constructive character.

All rights reserved.

Copyright Baleri Italia.

Patent pending and registered trademarks.

01/10/2025

Baleri Italia si riserva il diritto di apportare le eventuali modifiche di parti o dettagli ritenute opportune per ragioni di carattere produttivo o commerciale.

Tutti i diritti riservati.

Copyright Baleri Italia.

Modelli e Marchi depositati.

ZZ.CAT.001

Creative Direction
Alice Ballabio

Concept
Nicolò Maggioni

Photo
Silvio Macchi

Styling
Maria Trezzi

Pre-press
Monogramma, Cantù

Printed by/Stampato da
Grafica Gioia, Cantù

Acknowledgements/Ringraziamenti
Alessi S.p.A.
Società Benefit Lanerossi

